



Research to Support Integrated Management Systems of Aquatic and Terrestrial Invasive Species

A Collaborative
Partnership between
Mississippi State
University's
GeoResources Institute
and the
U.S. Geological Survey

Annual Report December 2005

Table of Contents

Page 4	Introduction
Page 5-15	MSU Investigators and Participants
Pages 16-26	Project Publications and Presentations
Page 27	Task 1. Aquatic Plants
Pages 28-31	Task 1.1. Aquatic Plant Remote Sensing
Pages 32-37	Task 1.2.1. Aquatic Plant Habitat Invasibility Models
Pages 38-41	Task 1.2.2. Aquatic Plant Virtual Plant Models
Page 42-44	Task 1.2.3. Growth of Giant Salvinia as Regulated by Water Quality Parameters
Pages 45-48	Task 1.3. Weed Risk Assessment of Roundleaf Toothcup [<i>Rotala rotundifolia</i> (Roxb.) Koehne]
Pages 49-52	Task 1.4.1. Construction of Experimental Facilities
Pages 53-60	Task 1.4.2. Environmental Impact of Invasive Aquatic Plants on Aquatic Habitat
Pages 61-63	Task 1.5. Invasive Aquatic Plant Database for the United States

Page 64 **Task 2. Terrestrial Plants**

Pages 65-72	Task 2.1. Terrestrial Plant Remote Sensing
Page 73	Task 2.2.1. Habitat Invasibility Models
Pages 73-74	Task 2.2.1.A. Habitat Invasibility Models
Pages 75-77	Task 2.2.1.B. Habitat Invasibility Models – Physical Belowground Interaction of <i>Imperata cylindrica</i> with Native Vegetation
Pages 78-80	Task 2.2.2. Terrestrial Plant Virtual Plant Models
Pages 81-87	Task 2.3. Federal Regulatory Weed Risk Assessment Beach Vitex (<i>Vitex rotundifolia</i> L. f.). Assessment Summary
Page 88	Task 2.4. Integrated Management Tactics for Cogongrass Control
Pages 88-89	Task 2.4.A. Cultivation Intensity for Cogongrass Eradication – Integrated Management. Tactics for Control

Page 90 Task 2.4.B. Cultivation Intensity for Cogongrass
Eradication – Integrated Management.
Tactics for Control

Page 91 **Task 3. Invasive Insects**

Pages 92 Task 3.1. Early Detection of Cactus Moth

Pages 92-95 Task 3.1.A. Early Detection and Reporting of Cactus
Moth: Sensory Structures of Larvae

Pages 96-99 Task 3.1.B. Detection and Reporting of Cactus Moth:
Protocols for Identification of Exotic and
Native Cactus Moths

Page 100 Task 3.2. Distribution of *Opuntia* in the Region

Pages 100-104 Task 3.2.A. Distribution of *Opuntia* in the Region

Pages 105-109 Task 3.2.B. Distribution of *Opuntia* in the Region –
Morphological and Genetic Analyses of a
Putative *Opuntia* Hybrid

Pages 110-113 Task 3.3. *Opuntia* Habitat Models

Pages 114 -115 Task 3.4. Optimization of a Nutria Spatial Model

Page 116 **Task 4. Extension and Outreach**

Page 117 Task 4.1. Aquatic Plant Extension Information

Pages 117-119 Task 4.1.1. Aquatic Plant Extension Information

Pages 120-121 Task 4.1.2. Aquatic Plant Management Extension
Information: Grass Carp Review

Page 122-123 Task 4.2. Terrestrial Grass Extension Information

Page 124-126 Task 4.3. Cactus and Cactus Moth Extension Information

Page 127-130 Task 4.4. Web-based Database of Invasive Species
Locations

Page 131 **Task 5. Regional Coordination**

Page 132-136 Task 5.1. Developing a State Invasive Species Alliance for
Mississippi

Page 137-140 Task 5.2 Mid-South ISA Formation

Introduction

Invasive species are an enormous problem for terrestrial and aquatic ecosystems in the United States, degrading their biodiversity and the ecosystem services they provide to our society. As a result, over the past decade federal and state agencies and nongovernmental organizations have begun to work more closely together to address it.

While awareness of the problem is becoming more widespread, efforts to address the threat are often piecemeal and fragmented, and new tools to deal with the problems are needed. In particular, the states in the Mid-South Region (AL, AR, LA, MS, and TN) need assistance in developing additional capacity, expertise, and resources for addressing the invasive species problem.

This report presents progress on a program of planned research, extension, and regional coordination for implementation by the GeoResources Institute (GRI) of Mississippi State University (MSU) in collaboration with the U.S. Geological Survey (USGS).

We propose three areas of directed, peer-reviewed research to enhance the management of invasive species: aquatic invasive plants, terrestrial invasive plants, and the renegade biocontrol agent, cactus moth (*Cactoblastis cactorum*). Specific results and deliverables are proposed for each of the main tasks described below. Specialists in USGS and other entities that are providing information, perspective, and/or oversight for the project are identified as collaborators. The research addresses invasive species issues that are often complex and require long-term cooperation.

MSU Investigators and Participants

Principal Investigator:

Dr. John Madsen, GeoResources Institute and Department of Plant and Soil Sciences

Mr. Clifton Abbott, GeoResources Institute

Dr. Richard Brown, Department of Entomology and Plant Pathology and the Mississippi Entomological Museum

Dr. Lori Bruce, Department of Electrical and Computer Engineering

Dr. John Byrd, Jr., Department of Plant and Soil Sciences

Dr. Eric Dibble, Department of Wildlife and Fisheries

Dr. Gary Ervin, Department of Biological Sciences

Dr. James Fowler, Department of Electrical and Computer Engineering

Dr. Victor Maddox, GeoResources Institute

Dr. David Shaw, GeoResources Institute and Department of Plant and Soil Sciences

Point of Contact:

Dr. John D. Madsen

GeoResources Institute

Box 9652

Mississippi State, MS 39762-9652

Ph 662-325-2428

Fax 662-325-7692

Email: jmadsen@gri.msstate.edu

www.gri.msstate.edu

Background summaries from each of the MSU participants are provided on the following pages.

John D. Madsen

As an undergraduate at Wheaton College in Illinois, I became intrigued by the relationship of plants with their environment. Working in plant ecology seemed a perfect opportunity to be paid to spend time outside. I attended University of Wisconsin-Madison, where I completed a Master of Science project on the aquatic plant communities of two trout streams in Wisconsin. My dissertation research at UW-Madison examined how a normally desirable native plant, sago pondweed, could become a nuisance problem in flowing water. Although I was a classically trained plant ecologist, I was beginning a journey into weed science. For my postdoctoral research, I worked on a recent invasion of Eurasian Watermilfoil (*Myriophyllum spicatum*) into pristine Lake George, New York. I studied all aspects of Eurasian Watermilfoil biology and ecology, from population studies on seeds and vegetation propagation, to physiological ecology and photosynthesis, and the impact of Eurasian Watermilfoil on native plant communities in that incredibly diverse lake from 1987 to 1990. In 1990, I left Rensselaer Polytechnic Institute to work at the US Army Engineer Research and Development Center field laboratory in Lewisville, Texas. For ten years, I worked as an aquatic plant ecologist with USAERDC on aquatic plant ecology and management literally across the country (with projects in Alabama, Alaska, California, Florida, Georgia, Idaho, Illinois, Kentucky, Louisiana, Minnesota, Mississippi, New York, North Carolina, South Carolina, Oregon, Tennessee, Texas, Vermont, Virginia, Washington, and Wisconsin). I left the USAERDC for a faculty position at Minnesota State University-Mankato for three years, where I taught limnology, plant ecology, wetland ecology, and environmental science. While I enjoyed teaching, I missed active research even more. I joined the faculty of Mississippi State University as Assistant Research and Extension Professor in 2003, with positions in GeoResources Institute and the Department of Plant and Soil Sciences. My responsibilities include coordinating research projects on invasive species in Mississippi, the southeastern US, and around the country. I am also responsible for education and outreach on invasive aquatic plants. I am a member of the Mississippi Aquatic Nuisance Species Task Force, serve on the board of the MidSouth Aquatic Plant Management Society, and am active in the Aquatic Plant Management Society, Southern Weed Science Society, and Weed Science Society of America. I am a past editor of the Journal of Aquatic Plant Management, past associate editor of Wetlands, and a former member of the editorial board of the Journal of Freshwater Ecology.

Clifton Abbott

My interest in computers started while in high school. That interest led me to taking college night courses during high school, thus setting my path towards computer science. During my time with Mississippi State University as a student (B.S. in C.S., 1995), I entered into the Cooperative Education Program. For two terms, I worked for International Business Machines (IBM) where I was responsible for setting up a test network for a banking system that was being developed for a Japanese bank. Being part of the test team, I developed software to wrap around certain modules of the system to mimic certain operational conditions. In addition to my work with IBM, I worked two terms with the Center for Air Sea Technology (CAST), an MSU research and development center located at the John C. Stennis Space Center. In 1995, my relationship with CAST became permanent. After being a team member on some smaller projects, the opportunity for me to take over a big contract as project manager and technical lead was presented to me. Though not as experienced as others, I jumped at the opportunity to take over the Naval Interactive Data Analysis System (NIDAS) contracted to the Naval Oceanographic Office. To date, NIDAS is one of the longest funded projects for MSU research with planning starting in 1992, and funding starting in early 1993. Though what was known as CAST is now part of the GeoResources Institute (GRI), opportunities continue to appear causing growth as my field of expertise widens. I have been the project manager and lead on several contracts with the Naval Oceanographic Office, the Naval Research Laboratory, and the Warfighting Support Center, and team players on many other contracts. I have served as software design/engineer, database design/administrator, system administrator, and web design/developer among others. My work at the Stennis Space Center has given me experience with oceanographic, atmospheric, and hurricane modeling. Some of my current work puts me in the depths of a system interfacing the web with a relational database to GIS mapping software for the cactus moth project.

Richard Brown

I began collecting insects during the 1960's in northwestern Arkansas. As a student at University of Arkansas (M.S., 1973), I became interested in the Lepidoptera, especially the "micros" of the southern Ozarks. After serving as a medical entomologist in the military for two years, I concentrated on the systematics of *Epinotia* and other tortricids at Cornell University. Upon completing my doctorate in 1980, I was employed as Director of the Mississippi Entomological Museum and Assistant Professor to teach taxonomy courses at Mississippi State University. Following collecting trips to Chile, Venezuela, New Caledonia and Fiji Islands, I began concentrating on the relatively unknown moth fauna in southeastern U.S., especially in unique and threatened habitats in Alabama, Louisiana, and Mississippi. In addition to faunistic work, I am continuing long term work on systematics of tortricid moths and am interested in evolution of wing patterns and the role of abiotic selection factors on feeding strategies and other adaptations. I am currently project director of the Mississippi Arthropod Survey, technical editor of the Mississippi Entomological Museum Publication Series, and organizer of the annual William H. Cross Expedition.

Lori Mann Bruce

Dr. Lori Mann Bruce is a native of Flintville, TN. She earned her Bachelor of Science degree in 1991 and Doctor of Philosophy degree in 1996 from the University of Alabama in Huntsville and her Master of Science degree in 1993 from the Georgia Institute of Technology. All three degrees are in Electrical and Computer Engineering.

Dr. Bruce is a Professor in Electrical and Computer Engineering at Mississippi State University. She is also the Director of the Signal Processing Research and Applications Laboratory at Mississippi State University. Prior to joining Mississippi State, Dr. Bruce was a faculty member at the University of Nevada, and she previously worked on the research staff of the U.S. Army Strategic Defense Command.

Dr. Bruce has been awarded approximately \$5million for her research in satellite remote sensing and medical imaging. Her work in remote sensing has led to the use of satellite imagery for detecting and tracking the spread of invasive species in the U.S. Her work in medical imaging has led to the design of computer aided diagnosis systems for the early detection of breast cancer. Dr. Bruce's research has primarily been funded by the National Aeronautics and Space Administration (NASA), the U.S. Department of Energy (DOE), and the National Science Foundation (NSF). She has been invited to present her research around the nation and the world, including Belgium, France, Italy, and Australia. Dr. Bruce's outstanding research has led to more than 85 refereed journal and conference publications.

Dr. Bruce has taught more than 40 courses, including graduate courses in the areas of digital signal processing, digital image processing, and automated target recognition, as well as undergraduate courses such as digital devices, electronics, and signals and systems. Dr. Bruce greatly values her role as an educator, and it is no surprise that she is well loved by her students. She has won several awards for her teaching and her work to increase the number of women and minorities in the engineering profession.

John D. Byrd, Jr.

John D. Byrd, Jr. was raised on a small tobacco, cotton and soybean farm near Hartsville, SC. His father's resistance to any herbicide other than Treflan provided an early opportunity to experience mechanical weed management, primarily, with cultivator and hoe, as well as weed biology, toting mature cockleburs out of the fields before they released seed. He spent a few summers employed at Coker's Pedigreed Seed Company getting first hand experience with hybrid corn development, but failed to appreciate the monotony of plant breeding.

It was not until he enrolled in a weed science course at Clemson University that he realized he could actually pursue a career studying weeds. He completed both M.S. and Ph. D. degrees at North Carolina State University in weed science, under the direction of Drs. Alan York and Harold Coble, respectively.

His real education began when he accepted a position at Mississippi State University as the Extension Weed Specialist for horticulture crops and cotton in 1989. His responsibilities were changed in 1992 to include all crops and noncropland. He was promoted to Professor of Weed Science and Extension Specialist in 1998. In addition, he coordinates and assists with in-service and continuing education weed control programs for county agricultural agents and numerous other groups involved with weed management.

Dr. Byrd's current research addresses emerging issues in weed science, including improved turf, pasture, and right of way weed management and management of noxious, invasive weeds of natural areas. He completed 1 M. S. and 2 Ph. D. students in 2005 and has six other M. S. graduate students. He has served on committees of more than 38 other graduate students.

Dr. Byrd has received several awards for his research and outreach activities, including the Education and Distinguished Service Awards from the Mississippi Weed Science Society, the Specialist Appreciation and Distinguished Service Awards from the Mississippi Association of County Agricultural Agents, Extension Award of Merit from Gamma Sigma Delta, the Service Award from the Mississippi State University Alumni Association, and the Outstanding Young Weed Scientist Award from the Southern Weed Science Society.

Eric Dibble

I am an Associate Professor of Ecology/Fisheries in the Department of Wildlife and Fisheries at Mississippi State University. I received my Ph.D. in ecology from the University of Arkansas (1992), and a MS and BS degree in biology from the University of Wisconsin (1979 and 1982, respectively). Previously to receiving my doctorate I worked as a teaching & research faculty at the University of Wisconsin, Menomonie, where I investigated exotic/invasive species in temperate lakes. For 25 years I have conducted research in littoral and riparian zone ecology with specific interests in the cause and effect of habitat alteration. This last decade, I have received considerable attention for my research on the potential impact that exotic/invasive aquatic plant species have on aquatic communities. I currently have on going research in southern reservoirs, Midwestern lakes, and tropical systems in Brazil. Much of this research has used experimental manipulation to isolate mechanisms responsible for the structural change in vegetated habitat important to growth, survival and maintenance of aquatic organisms (i.e., fishes and invertebrates). Prior to my current position I was a research biologist for the U.S. Army Corps of Engineers Aquatic Plant Control and Research Program. I have served as President for the Mississippi Chapter of the American Fisheries Society, and was invited to serve as Research Director at the Lake Superior Aquarium, Duluth, MN. I have graduated 3 PhD and 7 Masters students since starting at Mississippi State University, and currently serve as Undergraduate Student Coordinator for the Department of Wildlife and Fisheries.

Gary N. Ervin

As an undergraduate, I studied forestry at Mississippi State for three years, but later received my B.S. in Biological Sciences from The University of Alabama. During my final year of undergraduate work, I began conducting research on the biology of wetland plants, using radiocarbon methods to investigate carbohydrate allocation patterns in clonal perennial rushes. In 1997, I began Ph.D. studies in the Aquatic Biology Program at Alabama, during which time I expanded my studies of wetland plants to include seed ecology and interspecific interactions during vegetation succession in a former beaver pond. I then was employed as a post-doctoral researcher in the Department of Entomology at The University of Arkansas, where I worked on physiological and biochemical interactions between plants and insect herbivores, primarily larvae of heliothine moths. I began my present position as Plant Ecologist in the Department of Biological Sciences at Mississippi State University during 2001, and my work currently spans the areas of wetland plant ecology, wetlands bioassessment, and, of course, invasive species ecology – including such markedly non-wetland species as the prickly pear cacti that serve as hosts for *Cactoblastis cactorum*.

James E. Fowler

I received the B.S. degree in computer and information science engineering and the M.S. and Ph.D. degrees in electrical engineering in 1990, 1992, and 1996, respectively, all from the Ohio State University. In 1995, I was an intern researcher at AT&T Labs in Holmdel, NJ, and, in 1997, I held an NSF-sponsored postdoctoral assignment at the Université de Nice-Sophia Antipolis, France. In 2004, I was a visiting professor in the Département TSI at École Nationale Supérieure des Télécommunications (ENST), Paris, France. I am currently an associate professor in the Department of Electrical & Computer Engineering at Mississippi State University in Starkville, MS, and am also a researcher in the Visualization, Analysis, and Imaging Laboratory (VAIL) within the GeoResources Institute (GRI) at Mississippi State. I am currently an Associate Editor for *IEEE Signal Processing Letters*. My research interests center around the Communication of Images, Video, and Terascale Data, including image processing and coding, video coding, and data-communication systems. Specific areas of research include wavelet-based video and image coding; representation, compression, and ranked access of terascale datasets arising in scientific simulations; coding of geoscience data, particularly hyperspectral imagery; and image watermarking

Victor L. Maddox

I grew up in the Ozarks and developed an interest in plants at around age 10, and continue to collect plants for personal observations to this day. These include approximately 500 species of xerophytes, and hundreds of other plants with a living collection that includes flowering plants from over 200 families (over 1/3 of angiosperm families occurring on Earth), and numerous Pinophyta (conifers) and Pteridophyta (ferns and allies) species. I have a personal collection of approximately 5000 native and exotic plant pressed specimens, and a seed collection of grasses (over 500 species) and other plants (approx. 1000 global species). After attending Southeast Missouri State University, I received a B.S. in Horticulture with a minor in Botany. At Mississippi State University, I worked on algal species and population dynamics for my Master of Science thesis. I received a Ph.D. in Agronomy with a minor in Plant Taxonomy working with the management of five species of native grasses (29 selected ecotypes) for natural areas for my dissertation. I am interested in interdisciplinary invasive species projects requiring interdisciplinary teams to resolve issues impacting national ecosystems and economic security. I am also intrigued by the influence of human activities upon invasive species and subsequently natural ecosystems. Currently, I am a Postdoctoral Associate working with invasive species ecology and mapping, and *Opuntia* spp. ecological data collection and mapping in the United States. In this effort, I am a plant identifier, data collector, and mapper for a regional invasive species database and an *Opuntia* spp. Data Collector, Plant Identifier, and Dataform Verifier for the National Cactus Moth Detection and Monitoring Network database. Collaborators include GeoResources Institute, Mississippi Cooperative Extension Service, United States Geologic Survey, and the United States Department of Agriculture. I am a plant identifier for the Mississippi State University Cooperative Extension Service and various ecological and weed science research projects. In addition, I identify plants for the Mississippi Department of Agriculture, Bureau of Plant Industry. I have taught Plant Materials at Mississippi State University, and provided many guest lectures on various botanical topics at various forums. I have been a Consulting Botanist working on environmental reviews for the Tennessee Valley Authority (TVA) for approximately 10 years and I am a Plant/Weed Identifier for The Southern Plant Diagnostic Network (SPDN). I have assisted over 50 private and public landholders with task ranging from plant inventories to restoration plans and wetland delineations. I have served as a Board Member with the Institute for Botanical Exploration (IBE), directed by Dr. Sidney McDaniel.

David R. Shaw

I currently serve as the Director of the GeoResources Institute at Mississippi State University, a recently created institute at MSU that brought together the Mississippi Water Resources Research Institute, the Remote Sensing Technologies Center, the Computational Geospatial Technologies Center, and the Visualization, Analysis and Imaging Laboratory. I received my Ph.D. from Oklahoma State University in 1985, my M.S. from OSU in 1983, and his B.S. from Cameron University in 1981. I am also a William L. Giles Distinguished Professor at MSU. I began my career at Mississippi State in 1985 as an Assistant Professor of Weed Science, with research focused particularly on optimizing weed management practices to maintain farm productivity while improving surface water protection and management, and development of Best Management Practices for protection of surface waters from pesticides. Because of developmental efforts in applying spatial technologies to these research areas, MSU appointed me as the first Director of the Remote Sensing Technologies Center in 1998. More recently, I have focused on developing applications of spatial technologies in site-specific agriculture and in assessing natural resources. We currently work with numerous federal agencies, including NASA, US EPA, US DOT, USGS, DoC, NOAA, DoD, and NSF. Honors and awards include MSU's highest distinction as a William L. Giles Distinguished Professor in 1998, the Ralph E. Powe Research Award (MSU's highest recognition for research) in 2000, election as a Fellow in the Weed Science Society of America in 2002, the Outstanding Alumnus Award from Cameron University in 1999, and the Grantsmanship Award from the Mississippi Agricultural and Forestry Experiment Station in 1997. I am currently serving as the President for the Southern Weed Science Society, and also on the Board of Directors for the Universities Council on Water Resources.

Project Publications and Presentations

Journal Articles:

Burnell, K. D., G. N. Ervin, J. D. Byrd, Jr., and C. T. Bryson. 2005. Effects of foliage removal and nutrient addition on cogongrass (*Imperata cylindrica* (L.) Beauv) dominated areas. In Preparation. For submission to *Plant Ecology*.

Ervin, G. N. 2005. Temporal shifts in the relative importance of abiotic vs. biotic factors influencing invasion success. In preparation. For submission to *Plant Ecology*.

Ervin, G. N. 2005. Temporal scaling of the native-exotic species relationship mediated by microhabitat features and heterogeneity. In preparation. For submission to *Ecology Letters*.

Ervin, G. N., B. D. Herman, J. T. Bried, and D. C. Holly. 2005. Incorporation of invasive species information and wetland indicator status into wetlands floristic assessment indices. In Preparation. For submission to *Wetlands*.

Ervin, G. N., M. Smothers, C. Holly, C. Anderson, and J. Linville. 2005. Relative importance of wetland type vs. anthropogenic activities in determining site invasibility. In review. *Biological Invasions*.

Gray, C. J., J. D. Madsen, R. M. Wersal, and K. D. Getsinger. 2005. Eurasian watermilfoil and parrotfeather control using carfentrazone-ethyl. Submitted to *Journal of Aquatic Plant Management*.

Holly, D. C. and G. N. Ervin. 2005. Characterization and Quantitative Assessment of a Potential Rhizome-mediated Root Disturbance Mechanism in Cogongrass (*Imperata cylindrica* (L.) Beauv.). In Preparation. *Weed Biology and Management*.

Madsen, J. D. 2005. Eurasian watermilfoil invasions and management across the United States. *Currents: The Journal of Marine Education*, 21(2):21-26.

Slade, J. G., E. D. Dibble, P. C. Smiley Jr. 2005. Relationships between littoral zone macrophytes and the fish community in four urban Minnesota lakes. *Journal of Freshwater Ecology* 20: 636-640.

Proceedings Articles:

Gray, C. J., J. D. Madsen, R. M. Wersal, and K. D. Getsinger. 2005. Carfentrazone in combination with 2,4-D for the control of Eurasian watermilfoil

(*Myriophyllum spicatum*) and parrotfeather (*Myriophyllum aquaticum*). 2005 *Proceedings, Southern Weed Science Society*, 58:247.

Johnson, D. W., L. M. Bruce, "Spatial and Spectral Resolution Effects on the Use of Remotely Sensed Data for Detection of Invasive Species," *Proceedings, IEEE International Geoscience and Remote Sensing Symposium*, Seoul, Korea, July 25-29, 2005.

Madsen, J. D., J. D. Byrd, Jr., D. R. Shaw, and R.G. Westbrooks. 2005. Developing a state invasive species alliance for Mississippi. *2005 Proceedings, Southern Weed Science Society*, 58:253.

Madsen, J. D., and K. D. Getsinger. 2005. Selective control of invasive submersed aquatic plants. *Proceedings, Southeast Exotic Pest Plant Council 7th Annual Conference*, Birmingham, AL, May 3-5, 2005.

Slade, J. G., and E. D. Dibble. A habitat assessment of an herbicide application in four Minnesota Lakes. Mississippi Chapter of the American Fisheries Society, February 2005, Philadelphia, MS.

Slade, J. G., and E. D. Dibble. Evaluation of an herbicide application on vegetated habitat and the structure of a fish and macroinvertebrate community in Minnesota Lakes. North American Lake Management Society, November 2005, Madison, WI

Theses:

Slade, J. G. 2005. Evaluation of fish-habitat relationships following a species-specific herbicide treatment in Minnesota. Masters Thesis. Mississippi State University, 78 pp.

Extension Reports and Fact Sheets:

Abbott, C. 2005. GeoResources Institute, The Cactus Moth Detection and Monitoring Network Webpage. GeoResources Institute, Mississippi State University. http://www.gri.msstate.edu/cactus_moth

Cheshier, J. and J. D. Madsen. 2005. Common Reed (*Phragmites australis*): Description, Distribution, and Management. Invasive Species Fact Sheet, Mississippi State University Extension Service. In preparation.

Dibble, E. D. 2005. Invasive species: grass carp/ white amur (*Ctenopharyngodon idella*) Mississippi State University Extension. www.gri.msstate.edu/lwa/invspec/grass_carp.

Floyd, J. and J. D. Madsen. 2005. Survey Information for the National Cactus Moth (*Cactoblastis cactorum*) Detection and Monitoring Network. Invasive Species Report, Mississippi State University Extension Service. Submitted for publication.

Herman, B. D., J. D. Madsen, and G. N. Ervin. 2005. Development of Coefficients of Conservatism for Wetland Vascular Flora of North and Central Mississippi. In Review. GeoResources Institute, Mississippi State University.

Johnson, Kerry. 2005. Cactus cops. Mississippi Gardens Column. 25 July 2005.

Maddox, V., and J. D. Byrd, Jr. 2005. Cockspur pricklypear [*Opuntia pusilla* (Haw.) Nutt.] in Mississippi. Extension Fact sheet (in press).

Maddox, V., and J. D. Byrd, Jr. 2005. Devil's-tongue [*Opuntia humifusa* (Raf.) Raf.] in Mississippi. Extension Fact Sheet (in press).

Maddox, V., and J. D. Byrd, Jr. 2005. Erect pricklypear [*Opuntia stricta* (Haw.) Haw.] in Mississippi. Extension Fact Sheet (in press).

Maddox, V., and J. D. Madsen. 2005. Pricklypear Cactus (*Opuntia P.* Mill.) in Mississippi (in press).

Maddox, V., R. Westbrook, J. D. Byrd, Jr., and B. Brabson. 2005. Beach Vitex (*Vitex rotundifolia* L.f.). Extension Fact Sheet (in press).

Madsen, J. D. 2005. Curlyleaf Pondweed (*Potamogeton crispus* L.). Invasive Species Fact Sheet, Mississippi State University Extension Service. Submitted for publication.

Madsen, J. D. 2005. Eurasian watermilfoil (*Myriophyllum spicatum* L.). Invasive Species Fact Sheet, Mississippi State University Extension Service. Submitted for publication.

Robles, W. and J. D. Madsen. 2005. Waterhyacinth [*Eichhornia crassipes* (Mart.) Solms-Laub], Description, Distribution, and Management. Invasive Species Fact Sheet, Mississippi State University Extension Service. In preparation.

Robles, W. and J. D. Madsen. 2005. Hydrilla [*Hydrilla verticillata* (L.F.) Royle], Description, Distribution, and Management. Invasive Species Fact Sheet, Mississippi State University Extension Service. In review.

Wersal, R. M. and J. D. Madsen. 2005. Giant salvinia (*Salvinia molesta* Mitchell): Biology and Management. Invasive Species Fact Sheet, Mississippi State University Extension Service. Submitted for publication.

Wersal, R. M. and J. D. Madsen. 2005. The biology and management of parrotfeather [*Myriophyllum aquaticum* (Vellozo) Verdecourt]. Invasive Species Fact Sheet, Mississippi State University Extension Service. In review.

Wersal, R. M. and J. D. Madsen. 2005. Purple loosestrife (*Lythrum salicaria* L.). Invasive Species Fact Sheet, Mississippi State University Extension Service. Submitted for publication.

Westbrooks, R. G., J. D. Madsen, and R. L. Brown. 2005. Early Detection and Reporting of Cactus Moth in the U.S. Invasive Species Fact Sheet, Mississippi State University Extension Service. Submitted for publication.

Presentations on Projects:

International and National Meetings:

Baker, G. T. and R. L. Brown. 2005. Fine Structure and Function of *Sensilla* on Mouthparts and Antennae of *Cactoblastis cactorum* and related species, or Beauty is More than Skin Deep. Cactus Moth Symposium. Annual Meeting of Entomological Society of America, Fort Lauderdale, FL. Dec. 17, 2005.

Gray, C. J., J. D. Madsen, R. M. Wersal, K. D. Getsinger, A. G. Poovey, and L. A. M. Glomski. 2005. Eurasian watermilfoil (*Myriophyllum spicatum*) and parrotfeather (*Myriophyllum aquaticum*) control with carfentrazone-ethyl in combination with 2,4-D. Weed Science Society of America 45th Annual Meeting, 7-10 February 2005, Honolulu, HI.

Jernigan, J., and J. D. Madsen. 2005. Management of Eurasian watermilfoil for small-scale restoration of native vegetation in Mobile Delta, Alabama. Aquatic Plant Management Society, 10-13 July 2005, San Antonio, TX.

Madsen, J. D., J. D. Byrd, Jr., D. R. Shaw, and R. G. Westbrooks. 2005. Developing a State Invasive Species Alliance for Mississippi. Weed Science Society of America 45th Annual Meeting, 7-10 February 2005, Honolulu, HI.

Madsen, J. D., G. R. Ervin, R. Westbrooks, J. P. Floyd, A. Simpson, and E. Sellers. 2006. The National Cactus Moth Detection Network and Database. Abstract accepted for meeting, Ecological Society of America International Meeting, Merida, Mexico.

Mathur, A., L. M. Bruce, W. Robles, and J. Madsen. 2005. Feature Extraction via Spectro-Temporal Analysis of Hyperspectral Data for Vegetative Target Detection. Multi-temp 2005, The Third International Workshop on the Analysis of Multi-temporal Remote Sensing Images, 16-18 May 2005, Biloxi, MS.

Robles, W., J. D. Madsen, A. Mathur, and L. M. Bruce. 2005. Hyperspectral data to differentiate waterhyacinth from common rush. Aquatic Plant Management Society, 10-13 July 2005, San Antonio, TX.

Slade, J. G., and E. D. Dibble. Evaluation of an herbicide application on vegetated habitat and the structure of a fish and macroinvertebrate community in Minnesota Lakes. Aquatic Plant Management Society, July 2005, San Antonio, TX

Slade, J. G., and E. D. Dibble. Evaluation of an herbicide application on vegetated habitat and the structure of a fish and macroinvertebrate community in Minnesota Lakes. North American Lake Management Society, November 2005, Madison, WI

Wersal, R. M., J. D. Madsen, and B. R. McMillan. 2005. Environmental factors affecting biomass and distribution of *Stuckenia pectinata* in the Heron Lake System, Jackson County, Minnesota. Aquatic Plant Management Society, 10-13 July 2005, San Antonio, TX.

Regional and State Meetings:

Cheshier, J., R. Wersal, and J. Madsen. 2005. Comparison of three aquatic herbicides for the control of smartweed. MidSouth Aquatic Plant Management Society Annual Meeting, 11-13 October 2005, Tunica, MS.

Ervin, Madsen, Majure. 2005. Predictive Habitat Modeling in Support of Integrated Invasive Species Management in the Mid-South. First All-USGS Modeling Conference, Olympic Park Institute, WA, November 2005.

Ervin. 2005. Basic and applied ecology of invasive plants in Mississippi wetlands. Dept. of Sciences and Mathematics, MS University for Women, Columbus, Nov. 2005.

Ervin. 2005. Invasive plants in freshwater wetlands: Ecology and Assessment. Department of Biology, University of North Alabama, Florence, Oct. 2005.

Ervin, Herman, Bried, and Holly. 2005. Incorporation of exotic species and wetland affinity into assessment of wetlands floristic quality. Society of Wetland Scientists International Meeting, Charleston, SC, June 2005.

Ervin. 2005. Temporal shifts in the relative importance of abiotic vs. biotic factors influencing invasion success. Society of Wetland Scientists/Gulf Estuarine Research Society Joint Meeting, Pensacola Beach, FL, March 2005.

Ervin, Smothers, and Anderson. 2005. Relative importance of wetland type vs. local land use/cover in determining susceptibility to invasive plants. Association of Southeastern Biologists, Florence, AL April 2005.

Gray, C. J., J. D. Madsen, R. M. Wersal, and K. D. Getsinger. 2005. Carfentrazone in combination with 2,4-D for the control of Eurasian watermilfoil (*Myriophyllum spicatum*) and parrotfeather (*Myriophyllum aquaticum*). Southern Weed Science Society, 24-26 January 2005, Charlotte, NC.

Maddox, V., J. Byrd, and J. Madsen. 2005. Significant invasive species of the mid-south states. 24-26 Jan. 2005. 58th Annual Meeting of the Southern Weed Science Society, Westin Hotel, Charlotte, NC.

Madsen, J. D., and K. D. Getsinger. 2005. Selective control of invasive submersed aquatic plants. Southeast Exotic Pest Plant Council 7th Annual Meeting, 3-5 May 2005, Birmingham, AL.

Madsen, J. D., J. D. Byrd, Jr., D. R. Shaw, and R. G. Westbrooks. 2005. Developing a state invasive species alliance for Mississippi. Western Aquatic Plant Management Society 2005 Annual Meeting, 10-11 March 2005, Denver, CO.

Madsen, J. D., and T. E. Woolf. 2005. Ecology, life history, phenology, and management of curlyleaf pondweed in Minnesota. Western Aquatic Plant Management Society 2005 Annual Meeting, 10-11 March 2005, Denver, CO.

Madsen, J. D., J. D. Byrd, Jr., D. R. Shaw, and R. G. Westbrooks. 2005. Developing a state invasive species alliance for Mississippi. Southern Weed Science Society, 24-26 January 2005, Charlotte, NC.

Madsen, J. D. 2005. Selective control of invasive submersed aquatic plants. MidSouth Aquatic Plant Management Society Annual Meeting, 11-13 October 2005, Tunica, MS.

Robles, W., J. D. Madsen, A. Mathur, and L. Bruce 2005. Ground-truthed hyperspectral data for remote sensing of waterhyacinth. MidSouth Aquatic Plant Management Society Annual Meeting, 11-13 October 2005, Tunica, MS.

Slade, J. G., and E. D. Dibble. A habitat assessment of an herbicide application in four Minnesota Lakes. Mississippi Chapter of the American Fisheries Society, February 2005, Philadelphia, MS.

Slade, J. G., E. D. Dibble, and P. C. Smiley, Jr. Multi-scale relationships between littoral zone macrophyte and fish communities of east-central Minnesota. MidSouth Chapter of the Aquatic Plant Management Society, October 2005, Tunica, MS

Wersal, R., M. L. Tagert, and J. D. Madsen. 2005. Invasive plant survey of Ross Barnett Reservoir. MidSouth Aquatic Plant Management Society Annual Meeting, 11-13 October 2005, Tunica, MS.

Extension and Outreach:

Brown, R. L. 2005. Biology and Identification of Cactus Moth. Master Gardener's Workshop, Mississippi State University. May 19, 2005.

Brown, R. L. 2005. Native and Exotic Insects in Mississippi. Mississippi Geographic Alliance Summer Institute, Mississippi State University. July 14, 2005.

Christoloudou, Greg. 2005. The Cactus Moth: An Invading Pest. Mississippi 4H Entomology Camp, Lumberton, MS. July 19, 2005.

Maddox, Victor. Identification of Opuntia. Master Gardener Cactus/Cactus Moth Workshop. 19 May 2005. Mississippi State University, Landscape Architecture Building B, Mississippi State, MS.

Maddox, Victor. How to Fill Out Field Survey Forms. Master Gardener Cactus/Cactus Moth Workshop. 19 May 2005. Mississippi State University, Landscape Architecture Building B, Mississippi State, MS.

Maddox, Victor. Invasive plant species: Yard to yard. 6 Oct. 2005. Plant Materials I, Mississippi State University.

Maddox, Victor. Landscape conservation and the environment. 13-15 Nov. 2005. Mississippi Turfgrass Conference and Trade Show, Grand Casino Convention Center, Tunica, MS.

Maddox, Victor. The impact of hurricanes upon the spread of invasive species. Mississippi Vegetation Management Association Conference. 14-17 Nov. 2005. Meridian, MS.

Maddox, Victor. Cactus moth booth. Gulf Coast Garden and Patio Show. 25-27 Feb. 2005. Gulf Coast Coliseum, Biloxi, MS.

Maddox, Victor. Cactus moth booth. Jackson Garden and Patio Show. 11-13 Mar. 2005. Ag Center, Jackson, MS.

Madsen, J. D. 2005. A comparison of management techniques and the no-management option for invasive aquatic plants. 27th Annual Wisconsin Lakes Convention, 23-28 April 2005, Green Bay, WI.

Working Meetings:

Dibble, E. D., and J. G. Slade. 2005. Noted responses of fishes and invertebrate prey due to aquatic plant alteration in Minnesota Lakes. March 2005, Minnesota Department of Natural Resources, Annual Plant Management Meeting, St. Paul, MN.

Madsen, J. D. 2005. Point-Intercept Vegetation Survey Method –An Overview. Minnesota Department of Natural Resources Aquatic Plant Meeting, January, 2005. Fort Snelling, MN.

Madsen, J. D. 2005. Life History of Curly-Leaf And Effects On Native Plants. Minnesota Department of Natural Resources Invasive Aquatic Plant Management Meeting, January 2005. Bloomington, MN.

Madsen, J. D. 2005. Effects on Native Plants and Lake Condition of Not Treating Eurasian Watermilfoil. Minnesota Department of Natural Resources Invasive Aquatic Plant Management Meeting, January 2005. Bloomington, MN.

Madsen, J. D. 2005. Agency Coordination in Invasive Species Management. NOAA Site Visit, Mississippi State University. April 2005.

Madsen, J. D. 2005. The MSU GeoResources Institute Cactus Moth Project. MSU Cactus Modeling Meeting, Tunica, MS. February 2005.

Madsen, J. D. and C. Abbott. 2005. A web-based database for the National Cactus Moth Detection Network. NBII All-Nodes Meeting, 24-28 October 2005, Albuquerque, NM.

Madsen, J. D. 2005. Mississippi State University and the Invasive Species Information Node Partnership. NBII All-Nodes Meeting, 24-28 October 2005, Albuquerque, NM.

Madsen, J. D. 2005. Mississippi State University's Invasive Species Program: Relation to ISFS/NIISS. NASA/USGS Invasive Species Forecasting System Team Meeting, Fort Collins, CO. June 2005.

Madsen, J. D. 2005. Non-Chemical Aquatic Plant Management Techniques. Fanwort Management Meeting, Ontario Ministry of Natural Resources, Petersborough, Ont. June 2005.

Items of Pride:

Lucas Majure, a Master's degree student in the Department of Biological Sciences, was awarded an NSF Graduate Student Travel Award to attend an international scientific conference to be held in Merida, Mexico during January of 2006. The Ecological Society of America, in association with the Universidad Autónoma de Yucatán and the Centro de Investigaciones Científicas de Yucatán, is hosting a meeting entitled Ecology in an Era of Globalization: Challenges and Opportunities for Environmental Scientists in the Americas. Lucas' presentation, which is based on



research in support of Task 3, is entitled "Assessing habitat requirements for host plants (*Opuntia* spp.) of *Cactoblastis cactorum* in the Southeastern United States." That research is summarized in Task 3.3 – *Opuntia* habitat models.

Research in Dr. Gary Ervin's lab has involved four undergraduate students supported, in part, through an NSF-sponsored Research Experiences for Undergraduates Program in MSU's Department of Biological Sciences. Each year, these students produce posters on their summer research projects. Those posters can be viewed at: <http://www.msstate.edu/courses/ge14/REU/> (part of Dr. Ervin's web pages). The three projects produced by these students were:



Comparison of invasion in wetland communities

Melissa Smothers (Humboldt State University, Arcata, CA) and Cori Anderson (Birmingham Southern University)



Effects of existing vegetation and soil from three geographical areas of Mississippi on cogongrass (*Imperata cylindrica*) rhizome leaf growth

Brittany Garvin (University of South Carolina, Upstate)

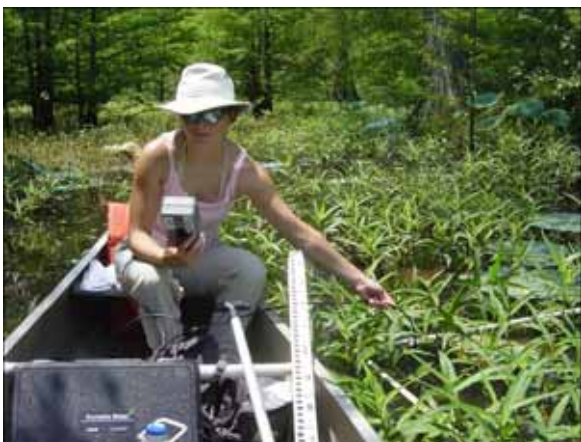

Alternanthera philoxeroides affects dissolved oxygen similarly to native littoral wetland vegetation

Erica Althans-Schmidt (Western Washington University)

John Madsen was quoted extensively in an article entitled “Vegetation Matters” by Mike Pehanich that appeared in Bass Times (ESPN.com) in August 2005. Dr. Madsen was quoted on the biology, ecology, and management of Eurasian watermilfoil (*Myriophyllum spicatum*).

John Madsen was one of three invited speakers from south of the border at a workshop on the invasive submersed species fanwort (*Cabomba caroliniana*), sponsored by the Ontario Federation of Anglers and Hunters and hosted by the Ontario Ministry of Natural Resources, 11-12 May 2005.

News and Press Releases:

GRI Collaborates to Create Database to Monitor Spread of Cactus Moth. Press Release. GeoResources Institute, Mississippi State University. March 4, 2005.

GRI Hosts Meeting of Cactus Moth Researchers. Press Release. GeoResources Institute, Mississippi State University. January 20, 2005.

Invasion of the Cactus Moth: A Serious Threat to Prickly Pear Cacti. Press Release. GeoResources Institute, Mississippi State University, Mississippi State, MS. June 4, 2006.

Master Gardener University Event Provides Workshop on the Mississippi State University GeoResources Institute Cactus Moth Project. 3 June 2005. GRI News: http://www.gri.msstate.edu/about/news/2005/master_gardener-06-03-2005.php. GeoResources Institute, Mississippi State University, Mississippi State, MS.

Mississippi Prepares to Battle Invasive Insects. 24 August 2005. <http://www.WLOX.com> WLOX, 208 DeBuys Road, Biloxi, MS.

NISC Agencies Team Up to Control the Spread of Cactus Moth. July 19, 2005. Stakeholder Announcement. www.invasivespecies.gov.

Recent Cactus Mapping and Modeling Workshop Hosted by GRI. February 22, 2005. GeoResources Institute, Mississippi State University.

The Cactus Moth: Friend Turned Foe. January 2005. USDA-APHIS CPHST News. Vol. II, Issue I.

Significant Meetings for Coordination:

Dr. Greg Smith, Director of the National Wetland Research Center, and Dr. Carroll Cordes, Branch Chief at NWRC, visit MSU concerning research coordination and collaboration. June 14, 2005.

John Madsen participated in a videoconference with NBII's Southern Appalachian Information Node (SAIN) on August 23 2005, and presented on invasive species efforts plans in the project that are relevant to SAIN. The cactus moth initiative in particular was emphasized.

John Madsen participated in a teleconference with the NBII's Invasive Species Information Node, Invasive Species Working Group (ISWG), on August 25, 2005. He presented the cactus moth web-based database specifically, and generally updated ISWG on the National Cactus Moth Detection Network.

John Madsen attended the Invasive Species Forecasting System Team meeting June 7-9, 2005 in Fort Collins, CO, of the NASA/USGS joint project on remote sensing of invasive species. He presented an update of the invasive species project at MSU in general, and highlighted progress on remote sensing.

Jacoby Carter, National Wetland Research Center's invasive species coordinator, visited GRI on April 4, 2005, to meet with James Fowler and John Madsen about collaborations in enhancing the computing speed of the nutria foraging model, and other potential modeling collaborations.

John Madsen attended the USGS / NBII All-Node Meeting 11-13 October 2005 in Albuquerque, NM and participated in a strategic planning session for the Invasive Species Information Node.

Task 1.

Aquatic Plants

Task 1.1. Aquatic Plant Remote Sensing

PI: Lori Bruce

Co-PI: John Madsen

Introduction:

Invasive aquatic plants affect drainage for agriculture and forestry, aesthetics, drinking water quality, commercial and sport fishing, fish and wildlife habitat, habitats for other plants, flood control, human and animal health, hydropower generation, irrigation, navigation, recreational boating, swimming, water conservation and transport, and, ultimately, land values [1]. If the distribution is limited, then locating and mapping invasive species is more successful. This puts a premium on early discovery and quick action. Cutting-edge technologies for remote sensing are likely to make detection less haphazard and lead to major advances in invasive species management. For example, multispectral and hyperspectral imagery collected with airborne or satellite sensors could provide a means for remotely detecting and/or monitoring the status of infestations.

In this project, ultra-high resolution data has been collected for a target aquatic invasive plant, waterhyacinth, and a non-target plant, American lotus. The goal is to analyze the ultra-high resolution data to determine how well the target invasive can be distinguished from surrounding non-target plants. This data was collected on a weekly basis during the summer of 2005, so multi-temporal analysis can be investigated. Also, the resolution (spatial, spectral, and temporal resolution) of the data was varied, so the effects of the resolutions on the target detection algorithms can be tested. This resolution analysis will be conducted in 2006, similar to that which has been completed on the terrestrial invasives as described in Task 2.1.

Materials and Methods:

Data Collection:

Field data and tank data were collected for waterhyacinth and American lotus. Waterhyacinth is chosen to be the target because it is an invasive aquatic weed and has multiple economic repercussions. American lotus is chosen as the non-target because it exists in similar environmental conditions as waterhyacinth, and it had a leaf structure similar to that of waterhyacinth. Hence, waterhyacinth and American lotus are a challenge to distinguish from one another using remotely sensed data. Figure 1 shows photos of waterhyacinth. Figure 2 shows sample hyperspectral signatures of waterhyacinth and American lotus.

For this study, the data is collected at regular intervals of time. The two aquatic plant species were populated in large tanks of water at a controlled site. Data was obtained every week. The time gap between two readings was between 6 to 8 days, depending on availability of clear sky days. Figure 3 shows an example collection of the hyperspectral readings.

The signatures were obtained with an Analytical Spectral Devices (ASD) Fieldspec Pro handheld spectroradiometer [2], which has a spectral range of 350 – 2500 nm, spectral resolution of 3 nm @ 700 nm and 10 nm @ 1400/2100 nm, and

uses a single 512 element silicon photodiode array for sampling 350 - 1000 nm and two separate, graded index Indium-Gallium-Arsenide photodiodes for the 1000 - 2500 nm range [2]. The signatures were taken in good weather conditions in Mississippi, U.S.A., in summer 2005 with the fiber optic sensor held NADIR at approximately shoulder height (4 feet) above ground. A 25° IFOV foreoptic was used, and the ASD unit was set to average ten signatures to produce each sample signature. Due to the probe's height and lens angle, the spatial resolution was approximately 0.22m. Care was taken to ensure that each measurement consisted of one end-member, i.e. a pure pixel. Thus, the spatial resolution is considered to be "perfect" since each signature represents a pure end-member pixel.



Figure 1. Waterhyacinth

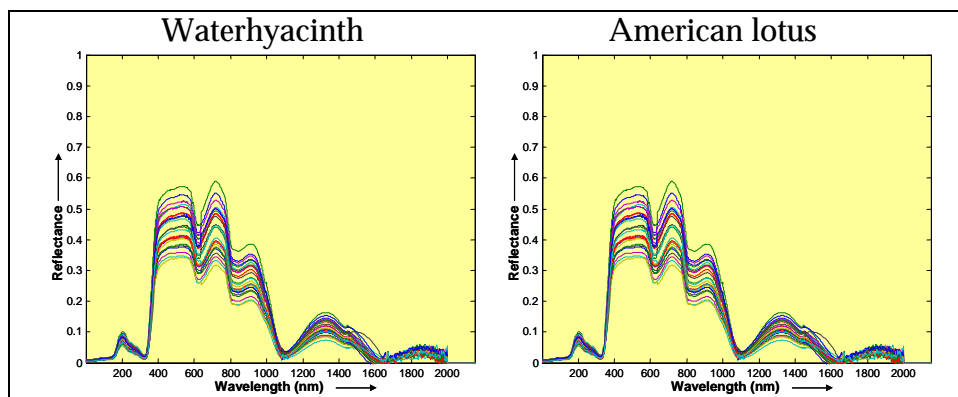

Figure 2. Sample hyperspectral signatures.



Figure 3. Example usage of a field spectroradiometer.

Data Analysis:

The eventual goal is to analyze the collected data while varying the spectral, spatial, and temporal resolutions, as described in Task 2.1 for terrestrial invasives. However, this could not be completed until the data was collected over summer 2005. Thus, the multi-resolution analysis will be conducted in 2006. In the meantime, preliminary analysis has been conducted on the aquatic invasives data.

The original hyperspectral signatures were input to an automated target recognition (ATR) system to determine how well the waterhyacinth (target) pixels could be discriminated from the American lotus (non-target) pixels in an ideal situation (having spectral resolution of approximately 1nm and ideal spatial resolution). The ATR system consisted of a feature extraction/reduction stage, where stepwise linear discriminant analysis (LDA) was used to select the best spectral bands, and a classification stage, where a nearest mean (NM) statistical classifier was employed [3-5]. The entire dataset was jack-knifed into equally sized, mutually exclusive training and testing sets. The training set was used to train the best band selection and the NM classifier. The testing set was then applied to the ATR system to produce confusion matrices along with producer, user, and overall accuracies [6].

Next, the multi-temporal aspect of the data was exploited. A new method was developed for organizing the hyperspectral, multi-temporal datasets into a spectro-temporal map [7]. Also, a new algorithm was developed to apply the stepwise LDA to the spectro-temporal maps.

Results and Discussion:

Table I shows the results when the original hyperspectral signatures were input to the ATR system. It should be noted that the multi-temporal aspect of the datasets were not exploited. The results shown in Table I are for one time instance. Table II shows the results when the stepwise LDA methods were applied to the spectro-temporal maps. As can be seen when comparing Tables I and II, the multi-temporal aspects of the remotely sensed data has a significant added value. However, it should be noted that these results are based on ultra-high spectral

resolution and high temporal resolution, which is not cost effective. Thus, the multi-resolution analysis is necessary.

Table I. Target detection results using LDA-NM system.

Nearest mean	Waterhyacinth	America Lotus	%
Waterhyacinth	111	49	69.37
America Lotus	21	139	86.88
Overall Accuracy			78.13

Table II. Target detection results using LDA-spectro-temporal map system.

Nearest mean	Waterhyacinth	America Lotus	%
Waterhyacinth	10	0	100
America Lotus	0	10	100
Overall Accuracy			100

Literature Cited:

H. W. Rockwell, Jr., “Summary of a Survey of the Literature on the Economic Impact of Aquatic Weeds,” *The Economic Impact of Aquatic Weeds*, August, 2003.

Analytical Spectral Devices FieldspecPro Spectroradiometer specifications. Available: http://asdi.com/products_specifications-FSP.asp

R.O. Duda, P.E. Hart, D.G. Stork, *Pattern Classification*, 2nd ed. New York, NY: John Wiley & Sons, Inc., 2001.

A. Mathur, L. M. Bruce, J. Byrd, “Discrimination of Subtly Different Vegetative Species via Hyperspectral Data,” *Proc. IEEE International Geoscience and Remote Sensing Symposium*, vol. 2, pp. 805 –807, 2002.

A. Mathur, L. M. Bruce, A. M. Cheriyyadat and H. H. Lin, “Hyperspec – Analysis of Handheld Spectroradiometer Data,” *Proc. IEEE International Geoscience and Remote Sensing Symposium*, Toulouse, France, July 2003.

R.G. Congalton and K. Green, *Assessing the Accuracy of Remotely Sensed Data: Principles and Practices*, Boca Raton: Lewis Publications, 1999.

A. Mathur, L.M. Bruce, “Feature Extraction via Spectro-Temporal Analysis of Hyperspectral Data for Vegetative Target Detection,” *Proc. Third Intl. Workshop on Analysis of Multi-temporal Remote Sensing Images*, May 16-18, 2005.

Task 1.2.1. Aquatic Plant Habitat Invasibility Models

PI: Gary Ervin, Co-PI: John Madsen

Introduction

Invasive species are a known and growing threat to native ecosystems and the services they provide. Freshwater wetlands are among the most productive ecosystems globally but also experience some of the highest rates of invasion. In a study of more than fifty Mississippi wetlands, approximately 10% of vascular plant species encountered were non-native, and 60% of the wetlands surveyed contained at least one plant species considered to be highly invasive. Furthermore, when highly invasive species were encountered, they were distributed across as much as 80% of the wetland area. In preliminary analyses used to develop a sampling scheme for habitat invasibility modeling, various approaches were implemented to determine environmental correlates with invasiveness in Mississippi's freshwater wetlands, including consideration of intrinsic ecosystem properties and extrinsic characteristics of the surrounding landscapes. The degree of invasibility of a diversity of wetlands was found to be much more strongly correlated with surrounding land use patterns than with the natural degree of connectivity among wetlands, and this pattern is supported by published data on invasive plants (Table 1.2.1-1).

Table 1.2.1-1. Correlations of land use/land cover characteristics on native and invasive species and assemblages.

Land Use/Cover	Direction	Effect on	Source
Agriculture cover	Negative	%Native spp. (all plants)	Lopez et al. 2002
" "	Negative	%Native woody spp.	" "
" "	Negative	%Native herbaceous spp.	" "
" "	Negative	%Native emergent herb spp.	" "
Forest cover	Positive	%Native spp. (all plants)	Lopez et al. 2002
" "	Positive	%Native herbaceous spp.	" "
" "	Positive	%Native emergent herb spp.	" "
" "	Negative	%Invasive emergent herb spp.	" "
Grassland cover	Positive	%Native herbaceous spp.	Lopez et al. 2002
Habitat fragment size	NONE	Invasive spp. richness, cover	Cully et al. 2003
Human visitation	Positive	Invasive spp. richness	Lonsdale 1999
Human activity Thompson 1997 (autos, soil transport, horticultural activities)	Positive	Invasive spp. dispersal	Hodkinson &
Paved roads	Negative	Native spp. richness	Gelbard & Belnap
2003			
" "	Positive	Inv. spp. richness, cover	" "
Roads	Positive	Invasive spp. frequency	Gelbard & Harrison
2003			
" "	Negative	Native spp. cover	" "
Roads and trails	Positive	Exotic weeds	Larson 2003
Roads and trails	Positive	Invasive pathogen dispersal	Jules et al. 2002

Within depressional wetlands across the state, invasibility was strongly correlated with surrounding land cover, with agricultural use positively correlated with invasion, and density of surrounding wetlands negatively correlated with invasion. Those correlations, however, were weak at best, indicating other variables will need to be incorporated into models designed to estimate the probability of encountering exotic plant species in freshwater wetlands. With these results in mind, the following sampling protocol was devised for data collection supporting development of habitat invasibility models in Mississippi and Alabama.

Materials and Methods

Studies to this point have focused simply on collecting data on wetland plant assemblages in a variety of regional wetland types, in order to determine potential correlations between vegetation characteristics (native species richness, absolute and relative richness of exotic species) and apparent degree of human-induced habitat disturbance or landscape-scale environmental attributes (land use & cover, thus far). These surveys have entailed collection of plant species data in systematically placed sample plots within arbitrarily selected wetlands within a given type or among several types (Photo 1.2.1-1).



Photo 1.2.1-1. Students from an NSF-sponsored Research Experiences for Undergraduates Program collect data on wetland vegetation. Those data are part of preliminary analyses used in guiding the design of sampling protocols for development of exotic species habitat models.

Analyses of data collected in 15 wetlands from five classes of wetland indicated that the degree to which wetlands were invaded was uninfluenced by wetland type, but was strongly correlated with level of human activity or habitat alteration in the immediately surrounding landscape (Figure 1.2.1-1., Ervin et al. *In Review*).

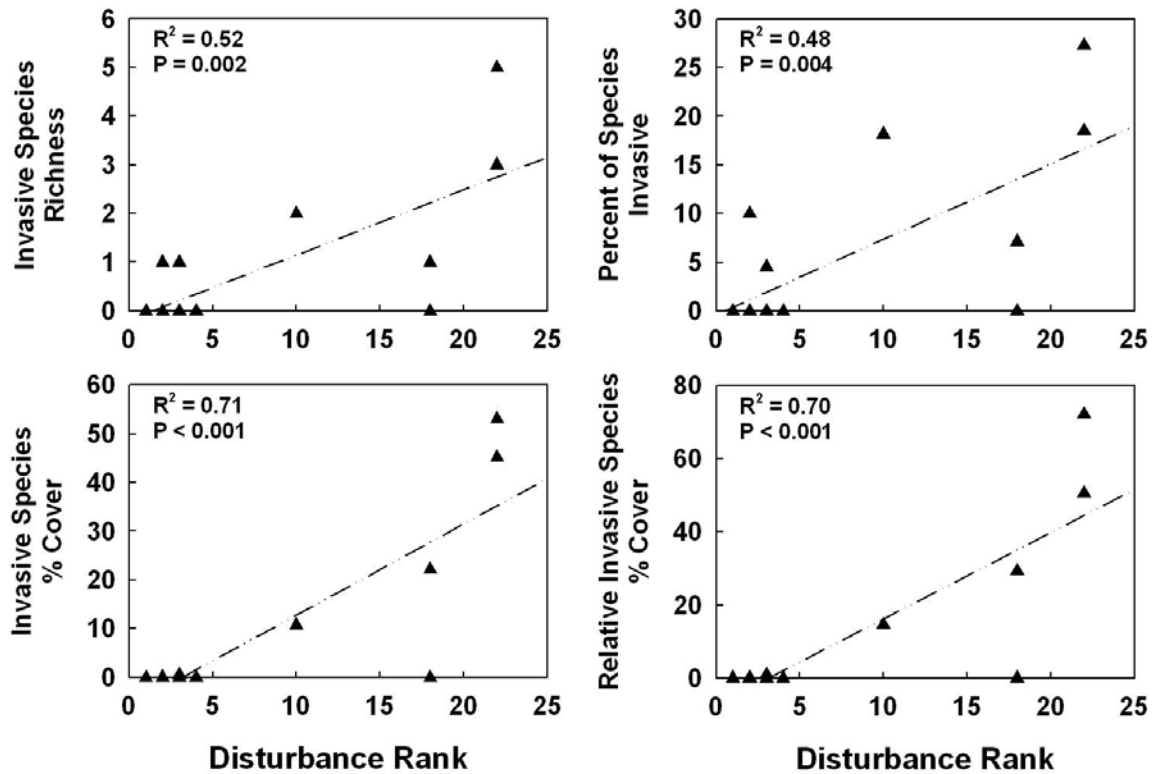

Figure 1.2.1-1. Wetland invasibility indicators correlated strongly with human-induced disturbance to the surrounding landscape.

Analyses of a larger dataset (53 depressional wetlands) also demonstrated connections between human activity and degree of invasion or vegetation quality (Figure 1.2.1-2., Ervin et al. *In Preparation*). However, those analyses demonstrated fairly weak direct correlations between land cover and invasibility. It is hypothesized that other geospatial or localized variables will improve the correlation between habitat characteristics and invasibility, and a sampling scheme has been devised for 2006 that will help to address deficiencies in current predictability.

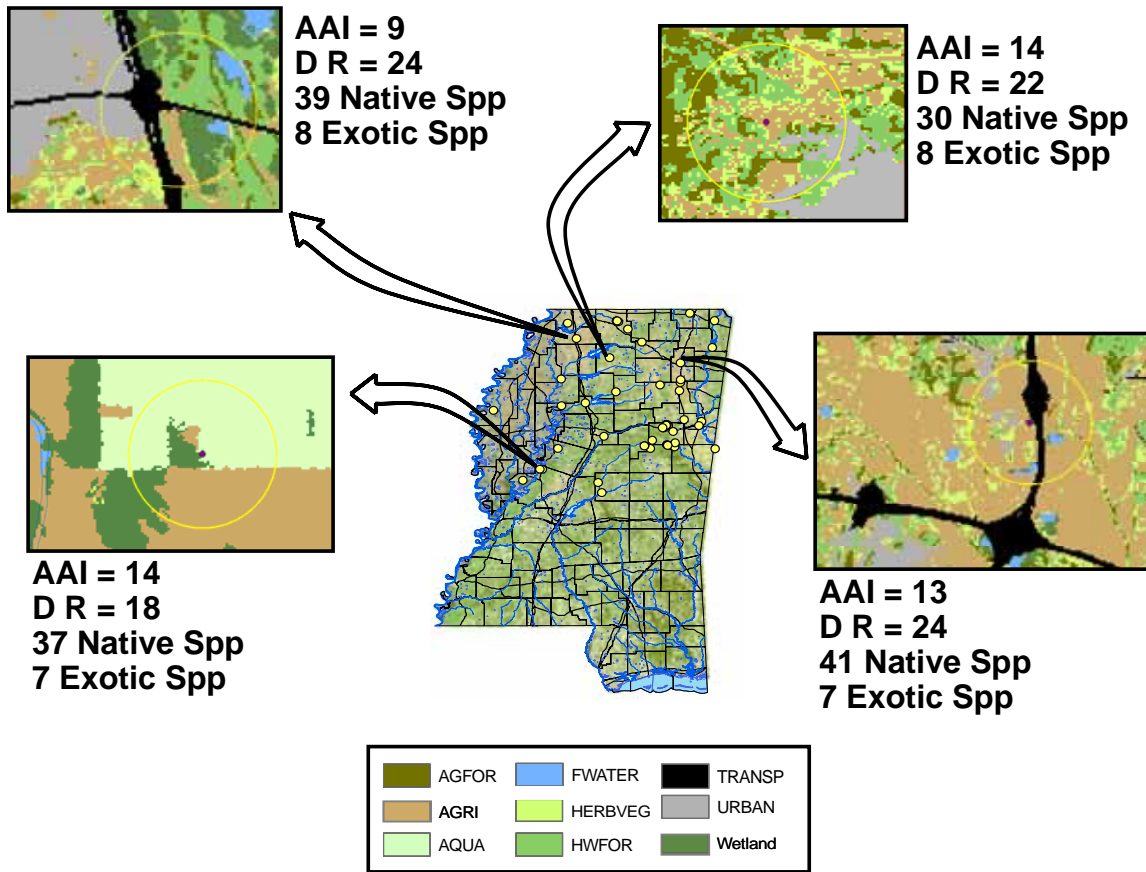

Figure 1.2.1-2. Examples of poorer quality depressional wetlands, as determined by Anthropogenic Activity Index (AAI), Disturbance Rank (DR), and floristic “quality.” These sites were characterized by a high density of urban or agricultural land use in the surrounding 1km buffer. Abbreviations: AG FOR = agroforestry; AGRI = agriculture; AQUA = aquaculture; FWATER = open freshwater systems; HERBVEG = low herbaceous vegetation; HWFOR = hardwood forest (presumably largely natural); TRANSP = transportation. Data from Vilella et al. 2003.

We have developed a stratified, randomly selected set of sample points that will be visited during the 2006 field season to collect vegetation and habitat data to be used in the development of statistical models to estimate the likelihood of exotic plant invasion. Points were located on federal public lands in Mississippi and Alabama, and were stratified based on the most recent compilation of land use/land cover data for the eastern Gulf Coastal Plain (Southeast Gap Analysis Project). Forty points were selected randomly from within each of the sixteen land cover classes, across national forests and refuges within the eastern Gulf Coastal Plain. At each of these points, we will collect data on plant species present and microhabitat characteristics (as per the Beyond NAWMA guidelines [Stohlgren et al. 2003], with

the addition of soil analyses), and augment those data with geospatial information, such as climatic data, land use/cover, soil associations, and proximity to such features as urban areas and transportation corridors. Data will be analyzed initially by correlation approaches, including linear and logistic regression. Other modeling approaches may be used, as deemed necessary and appropriate during analyses (e.g., GARP or other statistical approaches).

Literature Cited

Cully AC, Cully JF, Jr. and Hiebert RD. 2003. Invasion of exotic plant species in tallgrass prairie fragments. *Conservation Biology* 17: 990–998.

Ervin, G. N., B. D. Herman, J. T. Bried, and D. C. Holly. *In preparation*. Incorporation of invasive species information and wetland indicator status into wetlands floristic assessment indices. For submission to *Wetlands*.

Ervin, G. N., M. Smothers, C. Holly, C. Anderson, and J. Linville. *In review*. Relative importance of wetland type vs. anthropogenic activities in determining site invasibility. *Biological Invasions*.

Gelbard JL and Belnap J. 2003. Roads as conduits for exotic plant invasions in a semiarid landscape. *Conservation Biology* 17: 420–432.

Hodkinson DJ and Thompson K. 1997. Plant dispersal: The role of man. *Journal of Applied Ecology* 34: 1484–1496.

Jules ES, Kauffman MJ, Ritts WD and Carroll AL. 2002. Spread of an invasive pathogen over a variable landscape: A nonnative root rot on Port Orford cedar. *Ecology* 83: 3167–3181.

Larson DL. 2003. Native weeds and exotic plants: relationships to disturbance in mixed-grass prairie. *Plant Ecology* 169: 317–333.

Lonsdale WM. 1999. Global patterns of plant invasions and the concept of invasibility. *Ecology* 80: 1522–1536.

Lopez RD, Davis CB and Fennessy MS. 2002. Ecological relationships between landscape change and plant guilds in depressional wetlands. *Landscape Ecology* 7: 43–56.

Stohlgren, T. J., D. T. Barnett, and S. E. Simonson. 2003. Beyond North American Weed Management Standards. Available at: <http://www.nawma.org/documents/Mapping%20Standards/BEYOND%20NAWMA%20STANDARDS.pdf>.

Vilella, F. J., R. B. Minnis, R. D. Elmore, J. L. Bowman, D. L. Evans, and J. W. McCombs. 2003. A GAP Analysis of Mississippi. Final Report, Cooperative

Agreement No. 14-45-0009-1544-44. U. S. Geological Survey, Biological Resources Division, Mississippi Cooperative Fish and Wildlife Research Unit. Mississippi State, MS. 712 pp.

Task 1.2.2. Aquatic Plant Virtual Plant Models

PI: John Madsen

Collaborator: David Spencer, USDA-ARS, Davis, CA

Introduction

Nonnative invasive aquatic plants are a serious economic and ecological threat to the water resources of the United States. Invasive aquatic plants adversely affect flood control, commercial navigation, hydropower generation, and recreation. Greater than \$100M per year are spent on managing invasive aquatic plants in the United States, with a potential impact of unchecked plant growth at 15 times that amount (Rockwell, 2003). Invasive aquatic plants are also ecologically damaging. Nonnative aquatic plants reduce native plant growth and diversity, reduce biodiversity of all aquatic organisms, reduce the value of aquatic habitat for wildlife, impair water quality, and are a cause of species extinction (Madsen 1997).

With so much economic and natural capital at stake, better management of these species requires a better understanding of our opponent in this war on weeds. While our understanding of these species may progress at many levels of organization and investigation, one recent avenue that both assists in understanding the complex interactions of invasive plants with their natural environment and visualizing the impacts these species have is spatial modeling. The relatively new field of plant informatics allows for both the modeling of plant-plant and plant-environment interactions (Room et al., 1994), as well as realistic visualization of “virtual plants” (Room et al., 1996). This technique is already in use in agricultural research to predict weed-crop interactions, create virtual landscapes, and simulating crop plant architecture (Sonohat et al., 2002; Lane and Prusinkiewicz, 2002).

Task Description

The development of individual-based three-dimensional models of invasive aquatic plants will be scalable from plant-plant interactions to the landscape scale, and aid in the prediction of plant dispersal and growth. In addition, the development of these models will directly contribute to the visualization of invasive plants stands using the technology existing at VAIL. Rather than mathematical projections based on allometric relationships, plant visualizations can be projected from empirical data of plant stands at different life stages.

Common reed (*Phragmites australis*) will be modeled using this approach (Photo 1). Common reed is a widespread invader to wetlands and brackish estuarine environments, and seriously degrades wetland habitat value.



Photo 1. Common reed (*Phragmites australis*) in a Missouri roadside ditch. Photo by Victor Maddox.

Phragmites populations will be grown in six tanks. Air and water temperature will be monitored constantly using Onset HOBO dataloggers (or comparable), recording temperatures in each trough and in the air at 5-minute intervals.

Phragmites plants will be digitized using a Polhemus Fastrak 3-dimensional digitizer system, utilizing Floradig software (Hanan and Room, 2000). Plants in each tank will be digitized every other week from initiation of growth, beginning in early spring of 2006, until the end of the growing season. Digitized plant data will be processed using L-studio, a program that defines virtual plants from digital position data (Prusinkiewicz et al., 2000).

The experiment will be replicated at both the Mississippi State University's North Farm, and at the USDA-ARS Aquatic Weed Laboratory, located at University of California-Davis. Collaboration with Dr. David Spencer, of USDA-ARS, in collecting identical data in both locations had been planned. Dr. Spencer currently has a digitizing system identical to the one requested, and has been collecting virtual plant data in a study of giant reed (*Arundo donax*; Thornby et al, 2005; Figure 1). Conducting identical research in two locations will indicate if results are generalized, rather than site-specific.

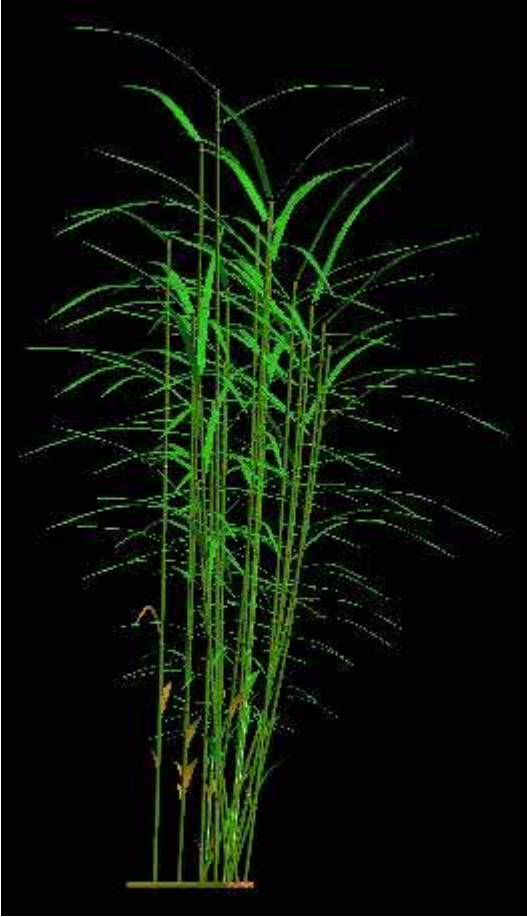

Figure 1. Giant reed (*Arundo donax*) virtual plant, developed by David Spencer, USDA-ARS.

Literature Cited

Hanan, J. and P. Room. 2000. Floradig User Manual. CSIRO Entomology, Brisbane, Australia. 51pp.

Lane, B. and P. Prusinkiewicz. 2002. Generating spatial distributions for multilevel models of plant communities. Proceedings of Graphics Interface 2002 (Calgary, Alberta, May 27-29, 2002), pp. 69-80.

Madsen, J.D. 1997. Chapter 12. Methods for Management of Nonindigenous Aquatic Plants, pp. 145-171. In: J.O. Luken and J.W. Thieret, eds. Assessment and Management of Plant Invasions. Springer, New York. 324pp.

Prusinkiewicz, P., J.S. Hanan, and R. Mech. 2000. An L-system-based plant modeling language. In: M. Nagl, A. Schurr, and M. Munch (eds.), Application of graph transformations with industrial relevance, Lecture Notes in Computer Science 1779, pp. 395-410, Springer-Verlag, Berlin.

Rockwell, H.W., Jr. 2003. Summary of a Survey of the Literature on the Economic Impact of Aquatic Weeds. Aquatic Ecosystem Restoration Foundation, Lansing, MI. 18pp.

Room, P.M., J.S. Hanan, and P. Prusinkiewicz. 1996. Virtual plants: New perspectives for ecologists, pathologists and agricultural scientists. Trends in Plant Science 1:33-38.

Room, P.M., L. Maillette, and J.S. Hanan. 1994. Module and metamer dynamics and virtual plants. Advances in Ecological Research 25:105-157.

Sonohat, G., H. Sinoquet, C. Varlet-Grancher, M. Rakocevic, A. Jacquet, J.-C. Simon, and B. Adam. 2002. Leaf dispersion and light partitioning in three-dimensionally digitized tall fescue-white clover mixtures. Plant, Cell, and Environment 25:529-538.

Thornby, D., D. Spencer, and J. Hanan. 2005. A growth model of the invasive weed species, *Arundo donax* L. (submitted to Aquatic Botany).

Task 1.2.3. Growth of Giant Salvinia as Regulated by Water Quality Parameters

PI: John Madsen, GeoResources Institute, Mississippi State University

Collaborator: Randy Westbrook, USGS National Wetland Research Center

Introduction

Giant salvinia (*Salvinia molesta*) is a relatively new invasive aquatic plant to the United States that has previously demonstrated both a high potential for spread and a high rate of growth (Oliver 1993). Giant salvinia is likely limited in its northward spread by freezing temperatures (Owens et al. 2004), but little is known concerning other environmental parameters such as nutrient availability and water pH. Previous studies have suggested that high pH will limit the growth of giant salvinia (Owens et al. 2005). Since this free-floating species derives its nutrients, predominantly nitrogen, from the water via root-like leaves, the availability of soluble nutrients might be a key element in predicting the success of the plant. We hypothesized that pH and water column nutrient concentration would both significantly affect the growth of giant salvinia.

Materials and Methods

The growth of giant salvinia was evaluated in a two factor (pH and nutrient level), with each factor having three levels. The three levels of pH were 5.0, 6.5, and 8.0. The three levels of nitrogen were 0, 30, and 45 mg L⁻¹ as nitrate. Each combination was replicated in three mesocosm tanks, with a total of eighteen tanks in the experiment. Air and water temperature were monitored constantly using Onset HOBO dataloggers (or comparable), recording temperatures in each treatment and in the air at 5-minute intervals. Water chemistry was monitored for dissolved nitrogen (nitrate), phosphorus (phosphate), and pH weekly. Growth was determined by biomass measured every other week, for fourteen weeks. The effects of pH and nitrogen level on growth were analyzed using ANOVA on the results for week eight.

Results and Discussion

Water pH treatments did not significantly affect giant salvinia growth after eight weeks of growth (Figure 1, left, $p=0.134$). In contrast, nitrate concentration significantly affected giant salvinia biomass development (Figure 1, right, $p<0.01$).

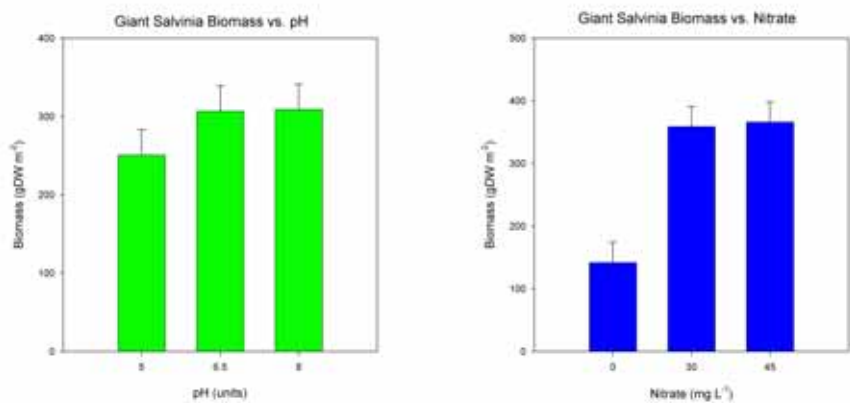

Figure 1. After eight weeks of growth, giant salvinia biomass (gDW m⁻²) was not affected by pH (left, p=0.13) but was significantly influenced by nitrate concentration in the water (right, p<0.001).

Interaction effects, based on a two way ANOVA, were not found. Plants grown without additional nitrate in the water grew significantly less than those grown at 30 and 45 mg L⁻¹ nitrate concentrations. Plants grown at low nitrate concentrations were significantly more chlorotic and less robust than those grown at the highest nitrate concentration ((Photos 1, 2).



Photo 1. Giant salvinia grown under conditions of low pH (pH of 5) and low nitrogen concentration (nitrate of 0 mg L⁻¹).



Photo 2. Giant salvinia grown under conditions of high pH (pH of 8) and high nitrogen concentration (nitrate of 45 mg L⁻¹).

Despite previous research suggesting that pH alone has a significant effect on waterhyacinth growth, our experimental study across a broader range of pH indicates that this variable is of limited importance other than in affecting nutrient availability. Nutrient availability, particularly that of available soluble nitrogen, limits giant salvinia growth. Further analyses of growth and tissue nitrogen concentration will provide additional insight into the interaction of water quality and giant salvinia growth.

Literature Cited

- Oliver, J.D. 1993. A review of the biology of giant salvinia (*Salvinia molesta* Mitchell). *Journal of Aquatic Plant Management*, 31:227-231.
- Owens, C.S., R.M. Smart and R.M. Stewart. 2004. Low temperature limits of *Salvinia molesta* Mitchell. *Journal of Aquatic Plant Management*, 42:91-94.
- Owens, C.S., R.M. Smart, D.R. Honnell, and G.O. Dick. 2005. Effects of pH on growth of *Salvinia molesta* Mitchell. *Journal of Aquatic Plant Management*, 43:34-38.

Task 1.3. Weed Risk Assessment of Roundleaf Toothcup [*Rotala rotundifolia* (Roxb.) Koehne]

PI: Randy G. Westbrooks, USGS BRD, Whiteville, North Carolina.

Collaborator: John Madsen, GeoResources Institute, Mississippi State University

Introduction

Roundleaf Toothcup (RTC) is an aquatic plant in the Lythraceae that is native to India (Purple Loosestrife is also in this plant family). RTC was first introduced to the United States as an ornamental aquatic pond plant (Rataj and Horeman, 1977). In recent years, it has been observed outside cultivation in northwest Alabama (Haynes, 2002) and south Florida (USGS Non-indigenous Aquatic Nuisance Species Database; USDA Plants Database). A recent field investigation of the population first reported around the periphery of a pond on the campus of the University of Alabama-Tuscaloosa revealed that the plant is still growing there, but in a reduced population due to campus housing construction.



Photo 1. Dr. Gary Ervin examines roundleaf toothcup at a manmade pond in Tuscaloosa, AL

Based on the native distribution of the plant in India, Roundleaf Toothcup occupies a very small percentage of its potential ecological range in the United States. However, it is expected that the plant would grow well in coastal communities throughout the southeastern U.S. from Virginia to Florida, and west to Texas.



Photo 2. Roundleaf toothcup (*Rotala rotundifolia*) grows emergent from the water in dense beds. In the same family as purple loosestrife, another aggressive aquatic weed, roundleaf toothcup has the potential to invade sites in the southeastern United States.



Photo 3. Close-up picture of a roundleaf toothcup inflorescence. No studies have been performed on seed production and viability in this species.

As a near relative of purple loosestrife, there is concern about the potential for RTC to become an invasive aquatic weed in the United States. The ability of the plant to reproduce from vegetative fragments (similar to Hydrilla), and its (apparent) ability to produce seeds, further raises such concerns. To help determine a proper course of action for addressing this new free living exotic plant, the U.S. Geological Survey, National Wetlands Research Center, and the Mississippi State University GeoResources Institute

will collaborate in 2006 to perform a qualitative risk assessment following the USDA APHIS Weed Risk Assessment Process. This will determine the pest risk potential for RTC, and whether it should be listed as a Federal Noxious Weed.

Under international agreements, a signatory country can only prohibit importation of quarantine pests. A quarantine pest is defined as “a pest of potential economic importance to the area endangered thereby and not yet present there, or present but not widely distributed and being officially controlled” (IPPC, 1995, 1996). Federally listed noxious weeds may not be imported into the United States or moved interstate without a special permit. Based on preliminary observations, already meets certain criteria for the listing process. It is of foreign origin, it has established free living populations outside of cultivation, and it is of very limited distribution. However, at this point, the overall pest risk potential for RTC has not been determined.

The weed risk assessment to be conducted in 2006 will complete Stages 1 and 2 of the weed risk analysis process as described below.

Materials and Methods

IPPC guidelines describe the three stages in Pest Risk Analysis including Pest Risk Assessment Initiation, Pest Risk Assessment, and Risk Management Planning. Following the APHIS Weed Risk Assessment Template, eight steps will be followed in completing stages one and two of the Pest Risk Analysis process, including:

Stage 1: Initiate the Process. Step 1: Document the Initiating Event; Step 2: Identify previous risk assessments; and Step 3: Establish the identify of the weed.

Stage 2: Conduct the Assessment. Step 4: Verify quarantine pest status; Step 5: Assess Economic and Environmental Consequences; Step 6: Assess Likelihood of Introduction; Step 7: Determine Pest Risk Potential; and Step 8: Document the Assessment with Literature Citations.

Results and Discussion

When completed the Cumulative Pest Risk Element Score for RTC will be presented in a Summary of Pest Risk Potential Ranking Table as shown below. This includes numerical scores for the **Consequences of Introduction** (Habitat Suitability, Spread Potential after Establishment, Economic Impact, and Environmental Impact), its **Likelihood of Introduction**, and its overall **Pest Risk Potential**.

Summary of Pest Risk Potential Rankings

I. Consequences of Introduction	II. Likelihood of Introduction	III. Pest Risk Potential = (II + III)
A. Habitat Suitability =		
B. Spread Potential After Establishment, Dispersal Potential =		
C. Economic Impact =		
D. Environmental Impact =		
CUMULATIVE RISK ELEMENT SCORE =		

Scores: High = 3; Medium = 2; Low = 1; Negligible = 0

Impact of Listing Roundleaf Toothcup as a Federal Noxious Weed

Based on the outcome of the assessment, the relative advantages of listing RTC as a Federal Noxious Weed will be presented.

Literature Cited

Rataj, K. and T. Horeman, 1977. Aquarium Plants, Their Identification, Cultivation, and Ecology. TFH Publications, Inc. Neptune City, New Jersey.

Haynes, R. 2002. Roundleaf Toothcup in Tuscaloosa County, Alabama. New Plant Record Note. Castanea 67:216.

IPPC, 1995. International standards for phytosanitary measures: Principles of plant quarantine as related to international trade (ISPM#1). IPPC & Food and Agriculture Organization of the United Nations. Rome.

IPPC, 1996. International standards for phytosanitary measures: Guidelines for pest risk analysis (ISPM#2). IPPC & Food and Agriculture Organization of the United Nations, Rome.

Task 1.4.1. Construction of Experimental Facilities

PI: John Madsen, GeoResources Institute, Mississippi State University

Introduction

Experimental research facilities, a mesocosm, were constructed or refurbished, two greenhouses, at the R.R. Foil Experiment Station (North Farm), Mississippi State University, Starkville, MS. A mesocosm facility was developed to allow for controlled replicated experiments to test the efficacy and species selectivity of herbicides in controlling invasive species (Dick et al. 1997); assess growth patterns of aquatic plants through manipulations of their environment to achieve a better understanding of the plant's ecology; and to assess the applicability of remote sensing as a strategy in controlling invasive species. Greenhouses were acquired for aquatic and terrestrial plants to propagate stock populations of desired species for use in experiments. These greenhouses are also equipped for experimental manipulations of desired plants.

Mesocosm

The mesocosm facility is 140 feet wide by 240 feet in length and encompasses approximately 0.7 acres, and has the capacity of approximately 500 tanks depending on tank size (Figures 1 and Photo 1 and 2).

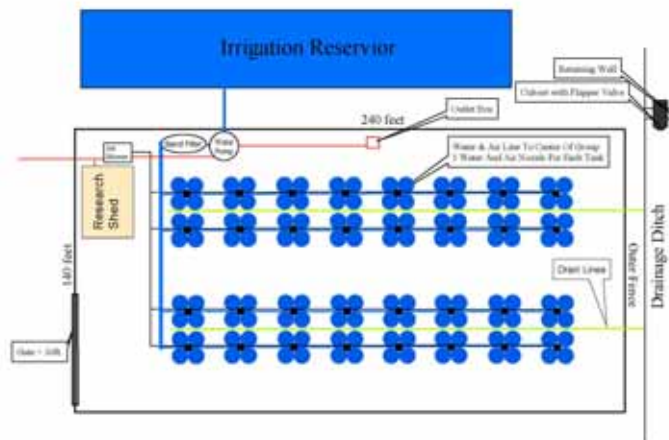

Figure 1. Schematic of the mesocosm facility located at the R.R. Foil Experiment Station, Mississippi State University.



Photo 1. Mesocosm facility near completion.



Photo2. A typical of block of tanks being used for manipulative research on invasive aquatic plants.

A clay-gravel pad was put down to allow for trenching and burying of approximately 2,700 feet of PVC for water and air supplies (Photo 3). Water and air lines were brought up from under ground to supply each block of tanks (Photo 4). Water is supplied via flooded suction method from a nearby reservoir and is pumped into the system using a 3 hp pump. A basket and sand filter are used to filter incoming water as it is pumped into the system. Aeration is supplied to each tank using a regenerative air blower. Drainage canals were constructed to drain water out the mesocosm and into a retention area outside of the main facility. Water is held in the retention area to monitor for herbicide degradation and growth of undesirable plants.



Photo 3. The initial phases of construction, the gravel pad and installation of the PVC water and air lines.



Photo 4. Water and air lines stubbed up out of the ground to supply water to experimental tanks.

Greenhouse

Greenhouses were acquired on the North Farm and refurbished from their original state (Photo 5). Tables were dismantled and removed along with all of the debris and dead plant material that accumulated from years of neglect. A pre-emergent herbicide was applied in the greenhouses to control weeds, followed by spreading new pea gravel to cover the ground inside the greenhouses. The plumbing and cooling wall were redone, and a new environmental control panel was installed. New tables were built in the aquatics greenhouse and metal tables installed in the terrestrial greenhouse. A mesocosm facility was also constructed in the aquatics greenhouse to complete the refurbishment (Photo 6).



Photo 5. The degraded aquatics greenhouse shortly after acquisition.



Photo 6. A refurbished aquatics greenhouse with mesocosm facility.

Literature Cited

Dick, G.O., K.D. Getsinger, and R. M. Smart. 1997. Outdoor mesocosm system for evaluation of aquatic herbicides: Operating manual. U.S. Army Corps of Engineers, Aquatic Plant Control Research Program, Miscellaneous Paper A-97-3.

Task 1.4.2. Environmental Impact of Invasive Aquatic Plants on Aquatic Habitat

PI: Eric Dibble

Co-PI: John Madsen

Student Research Assistants: Heather Theel; Alexander Perret; Amy Shaw

Student Technician: Johanna O'Keefe

The field phase of the following experiments were completed during this report period, supportive phases of laboratory assessment and data analysis are currently being conducted. Preliminary results from all experiments will be presented at two professional meetings this spring (2006): the Southeast Chapter of the North American Lake Management Society, and the Mississippi Chapter of the American Fisheries Society.

Experiment I: An evaluation of the effect of a non-native invasive macrophyte on juvenile largemouth bass habitat.

Introduction

Non-native macrophyte infestations in lakes and waterways of the United States in recent years have become a cause for concern. Some invasive macrophytes, such as the exotic hydrilla, *Hydrilla verticillata*, typically grow rapidly and form dense surface canopies that displace native vegetation (Colle and Shireman 1980; Keast 1984). In contrast, most native macrophytes provide open areas because of the variability in architecture due to size, number, and orientation of stems and leaves that increases largemouth bass foraging success (Colle and Shireman 1980; Killgore et al. 1989; Olson et al. 1998). Little is known about how fish habitat is impacted when a homogeneous plant bed replaces a heterogeneous bed of native vegetation. Changes in this structure within habitat can potentially impact growth, condition, and foraging ability of juvenile fish. It is speculated that the increased difficulty of capturing forage fish, resulting in a greater amount of energy required to capture prey, will result in slower growth and poorer condition (Colle and Shireman 1980; Dibble et al. 1996). Research is needed to better understand the ecological impact on aquatic communities, and how a shift from native plants to invasive exotics affect aquatic habitat. We investigated the hypothesis that exotic invasive plants alter juvenile largemouth bass (*Micropterus salmoides*) growth, condition, and foraging ability when diverse native plant beds are overgrown by exotic plant growth.

Materials and Methods

We conducted this experiment at two scales: i) in ponds, where we measured for differences in largemouth bass growth and condition between treatments of diverse native plants, and ii) in aquaria where foraging ability of juvenile largemouth bass is being quantified at different levels of replicated hydrilla invasions. Pond plantings constituted the following plants: (*Nymphaea odorata*, *Brasenia schreberi*, *Ceratophyllum demersum*, and *Potamogeton nodosus*) and invasive hydrilla (*Hydrilla verticillata*). In June 2005 six ponds were stocked with 50 juvenile largemouth bass

(45-70 mm) in each, 20 of which were tagged in order to record individual growth. Two ponds contained the diverse assemblage of vegetation, two were planted with hydrilla only, and two contained no plants at all. Juvenile redear sunfish (*Lepomis microlophus*) and fathead minnows (*Pimephales promelas*) were stocked in each pond to serve as a source of forage for the bass. Water quality and plant data were collected bimonthly for the four-month research period in order to compare the effects of each treatment. Fish were harvested in November 2005 at which time total lengths and weights were recorded.

In the aquaria experiments different levels of exotic plant invasion are being manipulated within the aquaria by increasing intervals (n=4) of introduced hydrilla (25% per treatment) from a 100% diverse native plant treatment to 100% hydrilla. Each treatment is separated into two sides by a divider, with three juvenile bass being placed on one side and 3 mosquitofish (*Gambusia affinis*) on the other. Fish are allowed to acclimate for 20 minutes before the divider is removed and the videography begins. Each bout lasts for no longer than 30 minutes at which time the fish are removed, the divider is replaced and the next acclimation begins. A total of 3 trials are being performed and each treatment will be replicated 5 times per trial yielding a total of 15 replicates per treatment. Video of the feeding bouts will be analyzed to compare the differences in foraging success between the treatments.

Preliminary Results

Largemouth bass collection from the ponds resulted in 72 from the diverse ponds, 56 from the hydrilla monoculture ponds, and 40 from the reference ponds. Although statistical analysis has not yet been conducted, we did observe differences in fish lengths and weights between the diverse and monoculture treatments. The diverse native treatment yielded the largest bass overall with an average final total length of 199.06 mm and average final weight of 97.31 g. The zero vegetation reference ponds produced final average total lengths and weights of 194.68 mm and 83.83 g, respectively. The hydrilla monoculture resulted in the smallest bass with an average final total length of 175.14 mm and an average final weight of 65.46 g. Fish are currently being inspected for tags in order to obtain individual growth data for analysis. Approximately 37% of the fish inspected to this date have retained their tags. This will allow us to assess the differences in individual growth in each treatment. Aquarium experiments are currently being conducted and foraging appears to be altered between the treatments.

Experiment II: Assessment of the influence of *Hydrilla verticillata* on structural habitat (alteration going from a heterogeneous to a homogeneous environment) and its impact on macroinvertebrate colonization and bluegill foraging efficiency.

Introduction

Aquatic plants contribute to the mediation of ecological interactions and processes in aquatic habitats, specifically predator-prey (bluegill-macroinvertebrate) interactions. Macroinvertebrate colonization is influenced by substrate heterogeneity, interstitial space, and surface complexity (Dibble et al. 1996a). High heterogeneous substrates often correlate with high macroinvertebrate abundance, density, and

richness (Schmude et al. 1998). Further, feeding and individual growth rates of many fish species are positively related to the abundance of macroinvertebrates (Diehl and Kornijow 1998). Exotic invasive plant species may provide habitat structurally different from habitat provided by native plants causing differences in structure for the macroinvertebrate community (Dibble et al. 1996b). Since macroinvertebrates provide a food base for young phytophilic fishes, changes in their density and abundance may significantly alter food web interactions (Cheruvilil et al. 2002).

This study is designed to determine community and behavioral responses to changes in habitat heterogeneity induced by the invasive aquatic plant, *Hydrilla verticillata*. Therefore, we investigated the hypothesis that a shift in a heterogeneous native aquatic plant bed to a homogenous invasive plant bed will alter aquatic habitat important to bluegill foraging and invertebrate colonization at the pond and aquaria level.

Methods

A field experiment was conducted in ponds and a laboratory experiment was conducted in aquaria. Macroinvertebrate colonization was evaluated in 3 different pond treatments with 2 replicate ponds per treatment. Treatments include: (1) heterogeneous (native) plant bed, (2) homogeneous (hydrilla) plant bed, and (3) no plants (reference). Plants were randomly planted in respective ponds according to proportional composition of plants found in the field. Invertebrates were sampled monthly in each pond from July to October 2005 using a sweep net and box sampler. Water depth temperature, pH, conductivity, and dissolved oxygen were also recorded at each sampling position. Once in the laboratory, macroinvertebrates will be separated from debris, enumerated, and identified to family.



Photo 1. A diverse native treatment pond in July 2005 that was dominated by the growth of the water lilies (*Nymphaea odorata*).



Photo 2. A hydrilla monoculture pond at the height of its growth in October 2005.



Photo 3. Light transmission was recorded in each pond bimonthly to compare plant effects between treatments.

Bluegill foraging was evaluated and compared in an observing aquarium between a heterogeneous (native) plant bed and a homogenous (hydrilla) plant bed, whereas each treatment represented an increasing density of hydrilla mimicking an invasion. Treatments included: (i) 100% native vegetation (control), (ii) 75% native vegetation and 25% hydrilla, (iii) 50% native vegetation and 50% hydrilla, (iv) 25% native vegetation and 75% hydrilla, (v) 100% hydrilla, (vi) 300% hydrilla, and (vii) no plants (reference). Each trial was composed of five replicates of all treatments (1-6) and three trials were conducted to obtain 15 replicates per treatment. A new bluegill was randomly selected for each replicate of each treatment and acclimated for 10 minutes within the aquarium's holding area. At the same time, six wax

worms were placed on permanent tethers in the vegetation bed to ensure uniform distribution. After the acclimation period, bluegill were released and allowed to forage for 15 minutes. All bluegill foraging activity were videotaped for further observation and assessment, and future analysis.



Photo 4. Stem counts were conducted using a 0.33 m² quadrat at 10 different points in each pond during bimonthly sampling.

Preliminary Results

Within the pond experiments, 270 macroinvertebrate samples were collected representing 36 families. Sample processing will be complete by December 2005. For the aquaria experiments, 1,575 minutes of bluegill foraging was recorded and all behavioral analyses will be completed by February 2006.



Photo 5. Largemouth bass 45-70 mm were measured for total length and weighed prior to being stocked into the treatment ponds.



Photo 6. Largemouth bass were tagged just behind the left eye with Visible Implant Alpha tags in order to track individual growth in each treatment.



Photo 7. Largemouth bass were measured for total length and weighed immediately after being harvested from their respective ponds.

Literature Cited

Cheruvilil, K. S., P. A. Soranno, J. D. Madsen, and M. J. Roberson. 2002. Plant architecture and epiphytic macroinvertebrate communities: the role of an exotic dissected macrophyte. *Journal of the North American Benthological Society* 21(2):261-277.

Colle, D. E., and J. V. Shireman. 1980. Coefficients of condition for largemouth bass, bluegill, and redear sunfish in hydrilla-infested lakes. *Transactions of the American Fisheries Society* 109:521-531.

Dibble, E. D., K. J. Killgore, and G. O. Dick. 1996. Measurement of plant architecture in seven aquatic plants. *Journal of Freshwater Ecology* 11: 311-318.

Dibble, E. D., K. J. Killgore, and S. L. Harrel. 1996b. Assessment of fish-plant interactions. *American Fisheries Society Symposium* 16:357-372.

Diehl, S., and R. Kornijow. 1998. Influence of submerged macrophytes on trophic interactions among fish and macroinvertebrates. Pages 24-46 in E. Jeppesen, M. Sondergaard, M. Sondergaard, and K. Christofferson, editors. *The structuring role of submerged macrophytes in lakes*, volume 131. Springer-Verlag, New York.

Keast, A. 1984. The introduced aquatic macrophyte, *Myriophyllum spicatum*, as habitat for fish and their invertebrate prey. *Canadian Journal of Zoology* 62:1289-1303.

Killgore, K. J., R. P. M. II, and N. B. Rybicki. 1989. Distribution and abundance of fishes associated with submersed aquatic plants in the Potomac River. *North American Journal of Fisheries Management* 9:101-111.

Olson, M. H., and coauthors. 1998. Managing macrophytes to improve fish growth: a multi-lake experiment. *Fisheries Management* 23(2):6-12.

Schmude, K. L., M. J. Jennings, K. J. Otis, and R. R. Piette. 1998. Effects of habitat complexity on macroinvertebrate colonization of artificial substrates in north temperate lakes. *Journal of the North American Benthological Society* 17(1):73-80.

Task 1.5. Invasive Aquatic Plant Database for the United States

PI: John Madsen

Collaborators: Pam Fuller, USGS, Florida Integrated Science Center, Tom Stohlgren, USGS FORT; Randy Westbrooks, USGS NWRC

Introduction

A large number of invasive aquatic plant species have become introduced into the United States. While several agencies have developed databases for tracking the locations and status of these invaders, these agencies do not have the resources to thoroughly track the presence and locations of these species in the states, relying instead on voluntary reporting of locations.



Photo 1. Waterhyacinth (*Eichhornia crassipes*) is a widespread invasive aquatic plant in the southern United States.



Photo 2. Eurasian watermilfoil (*Myriophyllum spicatum*) is a widespread submersed invasive aquatic plant throughout the United States.

Approach

We will contact representatives of state and federal government agencies in all fifty states regarding the locations of listed invasive aquatic plants, requesting information to populate the national invasive species database. In the process, we will also inform them of the availability of these web pages for their use – as both customers of information, and contributors. We will also attempt a limited amount of verification, as needed. We will provide the data to USGS and others, as appropriate. We will follow North American Weed Management Association (NAWMA) standards in collecting data from state partners.



Photo 3. Waterchestnut (*Trapa natans*) is a floating invasive aquatic plant significant to the northeastern portion of the United States.



Photo 4. Egeria (*Egeria densa*) causes localized problems in many regions of the United States.

Results

We have developed a contact list of over 200 individuals in federal, state, and local agencies and non-governmental organizations that may have data on specific locations of invasive aquatic plants. Our next step will be to actively solicit contribution of data from these individuals. We are waiting to contact these individuals until we have an easy mechanism for data contribution, such as a web-based interface.

Future Work

After the development of our invasive species web-based database data contribution page, we will be contacting these individuals to contribute data on the occurrence of specific invasive aquatic plant species of national and regional importance.

Task 2.

Terrestrial Plants

Task 2.1. Terrestrial Plant Remote Sensing

PI: Lori Bruce, GeoResources Institute, Mississippi State University

Co-PI: John Byrd, Plant and Soil Sciences, Mississippi State University

Introduction:

Remote sensing is an assessment technique that has yet to be fully exploited for invasive terrestrial plants. Most current approaches utilize either fixed-wing photography or commercial satellite imagery, both of which are relatively expensive for the product. Less expensive options include federal satellite imagery, such as those available from NASA's Landsat, MODIS, or Hyperion sensors. In order to best utilize the remotely sensed data for monitoring aquatic invasives, we need to determine the optimum sensor for the application. To determine the optimum sensor, we must be able to measure the effects of the sensor's spatial, spectral, and temporal resolution on our ability to detect the target invasive plant. To this end, we have collected field measurements and developed software to determine which resolutions produce the highest detection accuracies for specific target invasive plants.

Materials and Methods:

The goal is to determine which resolutions (spatial, spectral, and temporal) are best for detecting the target invasive plant. Our approach is to collect datasets with the highest possible resolutions, then degrade the resolutions and measure the effects. We have adhered to the following protocol:

- 1) for both the target invasive and potentially confusing nontarget plants, collect pure endmember, hyperspectral datasets using a handheld spectroradiometer to obtain maximum resolutions
- 2) systematically degrade the resolutions to produce datasets with varying resolutions
- 3) apply target detection algorithms to each dataset and examine results to determine which resolutions produce the highest target detection accuracies

Data Collection:

Field data were collected for Johnsongrass and Cogongrass. Cogongrass (*Imperata cylindrica* (L.) Beauv.) is a noxious invasive species prevalent in southeastern portions of the United States [1]. Johnsongrass (*Sorghum halepense* (L.) Schrad.) is also an invasive species found in the southern United States [2]. Figure 1 shows snapshots of Cogongrass and Johnsongrass taken in southeast Mississippi in summer 2004 and summer 2005. Figure 2 shows sample hyperspectral signatures for each class. Cogongrass and Johnsongrass are both long stemmed grasses and therefore have very similar spectra, as can clearly be seen from Figure 2. Hence, Cogongrass and Johnsongrass are a challenge to distinguish from one another using remotely sensed data.

The signatures were obtained with an Analytical Spectral Devices (ASD) Fieldspec Pro handheld spectroradiometer [3], which has a spectral range of 350 – 2500 nm, spectral resolution of 3 nm @ 700 nm and 10 nm @ 1400/2100 nm, and uses a single 512 element silicon photodiode array for sampling 350 - 1000 nm and

two separate, graded index Indium-Gallium-Arsenide photodiodes for the 1000 - 2500 nm range [3]. The signatures were taken in good weather conditions in Mississippi, U.S.A., in 2004-2005 with the fiber optic sensor held NADIR at approximately shoulder height (4 feet) above ground. A 25° IFOV foreoptic was used, and the ASD unit was set to average ten signatures to produce each sample signature. Due to the probe's height and lens angle, the spatial resolution was approximately 0.22m. Care was taken to ensure that each measurement consisted of one end-member, i.e. a pure pixel. Thus, the spatial resolution is considered to be "perfect" since each signature represents a pure end-member pixel.

In total, 286 and 130 measurements were collected for the Cogongrass and Johnsongrass classes, respectively. These signatures were then used to simulate lower spectral and spatial resolution data.



Figure 1. Cogongrass and Johnsongrass pictures. (a) Cogongrass image taken in southern Mississippi, U.S.A. Note that there is a black pen in the right hand side of the image for a size reference. (b) Johnsongrass image in northern Mississippi.

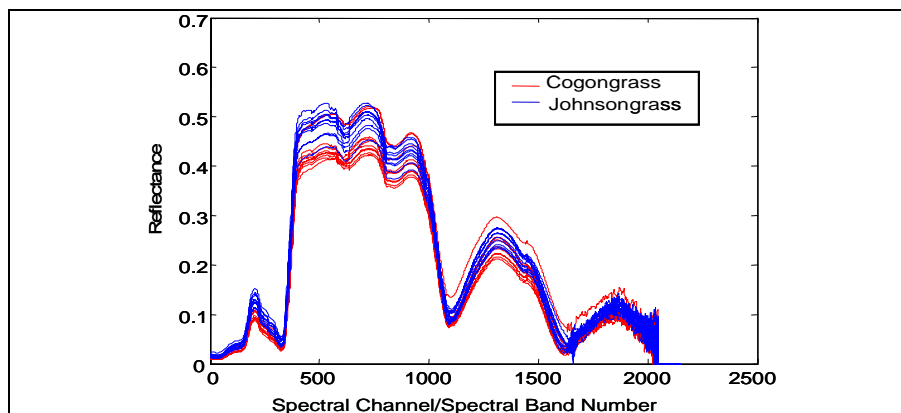

Figure 2. Example hyperspectral signatures of Cogongrass (red) and Johnsongrass (blue) from the original non-degraded dataset.

Data Analysis:

The original hyperspectral signatures were input to an automated target recognition (ATR) system to determine how well the Cogongrass (target) pixels

could be discriminated from the Johnsongrass (non-target) pixels in an ideal situation (having spectral resolution of approximately 1nm and ideal spatial resolution). The ATR system consisted of a feature extraction/reduction stage, where stepwise linear discriminant analysis (LDA) was used to select the best spectral bands, and a classification stage, where a maximum likelihood (ML) statistical classifier was employed [1,4-6]. The entire dataset was jack-knifed into equally sized, mutually exclusive training and testing sets. The training set was used to train the best band selection and the ML classifier. The testing set was then applied to the ATR system to produce confusion matrices along with producer, user, and overall accuracies [7]. Next, the spectral and/or spatial resolutions of the data were decreased, so as to simulate lower resolution datasets. In each case, the ATR system was retrained and tested on the lower resolution datasets.

The spectral resolution was decreased by using a moving average that simulated a uniformly distributed filter. Using this approach, the original hyperspectral signatures were spectrally degraded, resulting in 28 datasets with spectral resolutions of FWHM=[1, 2, ... 9, 10, 20, ..., 90, 100, 200, ..., 900, 1000nm]. Additionally, specific spectral resolutions were created in order to simulate various satellite sensor profiles. These included the TRWIS-D, Hyperion, TRWIS-B, TRWIS-2, CASI, ALI, GEOSAT, IKONOS, and RDACS sensors. In each case, appropriate modulation transfer functions were used with the original hyperspectral signatures to simulate the sensor's corresponding spectral signatures. Figure 3 shows example signatures of Cogongrass and Johnsongrass data spectrally degraded by a factor of 200. Figure 4 shows the entire dataset when spectrally degraded to simulate the Ikonos satellite sensor.

Lower spatial resolution datasets were created by using a linear mixing model. The two end-members were Cogongrass and Johnsongrass, where the Johnsongrass signatures were retained as "pure" pixels and the Cogongrass signatures were linearly mixed with Johnsongrass signatures to simulate "mixed" pixels. Thus, the two classes were Johnsongrass (background non-target vegetation) and Cogongrass-Johnsongrass (Cogongrass now being a subpixel target). The original spectral signatures were spatially degraded, resulting in 10 datasets with Cogongrass abundances in the mixed, target pixels equal to [10,20,... 90,100%]. Furthermore, the lower spatial resolution datasets were created using data with the original high spectral resolution as well as all degraded spectral resolutions and sensor profiles. Figure 5 shows an example of the dataset with the original spectral resolution and a spatial resolution of seventy percent. That is, the dataset has been altered to represent the condition where only seventy percent of a mixed, target pixel is Cogongrass.

Using the ATR system and the spectrally and spatially degraded datasets, spectral-spatial resolution accuracy maps were produced. Where the overall accuracy is recorded for each scenario in the map. These maps were then used to show how the classification accuracies varied with respect to different spectral and spatial resolution combinations.

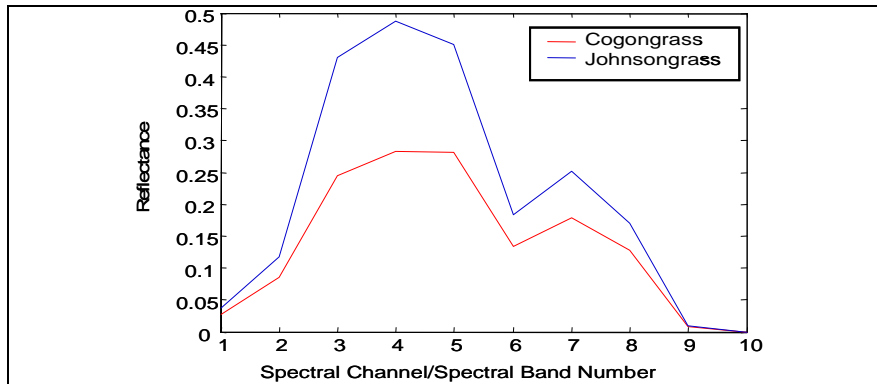

Figure 3. Example signatures of Cogongrass (red) and Johnsongrass (blue) where spectral degradation has been applied resulting in spectral resolution of approximately FWHM=200nm.

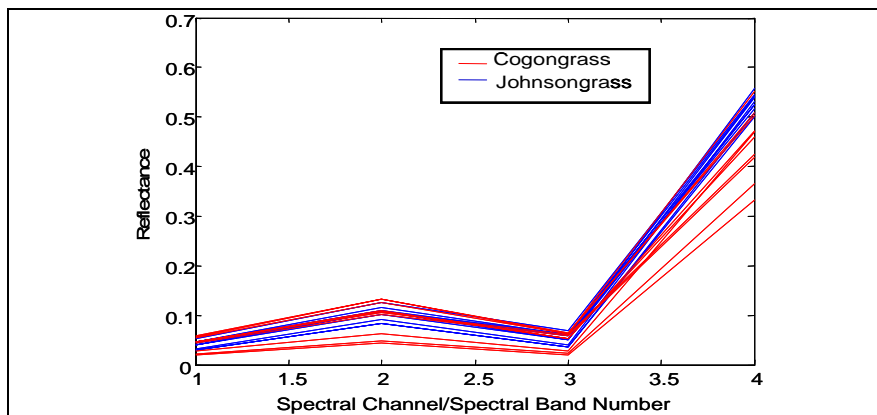

Figure 4. Example signatures of Cogongrass (red) and Johnsongrass (blue) where spectral degradation has been applied to simulate the IKONOS sensor.

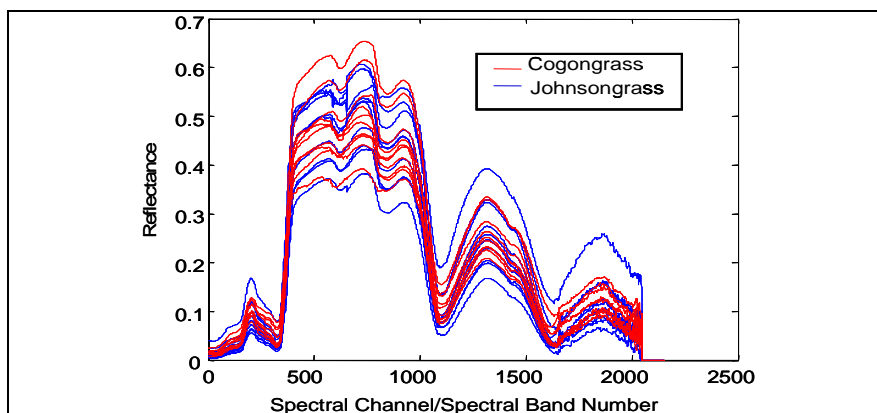

Figure 5. Example signatures of mixed-Cogongrass (red) and Johnsongrass (blue) where spatial degradation has been applied resulting in mixed, target pixels having Cogongrass abundance of 70%. Note: no spectral degradation was applied.

Results and Discussion:

Results show that the ability to discriminate between Cogongrass and Johnsongrass generally decreases as spectral and spatial resolutions decrease, as would be expected. Figure 6 shows the overall accuracies for the original dataset with the varying spectral degradations. The overall accuracy for the original dataset was approximately 90%. The overall accuracies fell below 80% around spectral resolutions of FWHM=300nm when the spatial resolution was not degraded (i.e. pure end-member classes). Figure 7 shows the accuracies for the various sensor profiles when no spatial degradation was applied. Of the sensor profiles simulated, the Trwis D and GeoSat profiles have the best and worst performances of approximately 95% accuracy and 55% accuracy. Figure 8 shows the overall accuracies obtained when the original spectral resolution data was spatially degraded. The overall accuracies remained above 70% as long as Cogongrass represented $\geq 80\%$ of the mixed pixel.

Figure 9 shows the spectral-spatial resolution accuracy map. The accuracy trends are similar to those of spectral and spatial resolutions alone. That is, as spectral and/or spatial resolution improved, the overall classification accuracy typically improved. However, upon close inspection of the accuracy map, we can see that a slight spectral degradation can actually improve the accuracies. Also, consider the area of the accuracy map where the spectral resolution is approximately FWHM=30-50nm, the Cogongrass mixed pixels can be detected even for low target abundance, 20-40%. This area of the map indicates that a significantly lower spectral and spatial resolution sensor could be used for this particular target/non-target application.

Overall results show that the ability of an ATR system to accurately distinguish between two different classes tends to be proportional to available spectral and/or spatial resolutions. The achieved accuracies were surprisingly good, in that despite large amounts of signature degradation, there were rarely any instances when the decision between two classes was simply a guess, i.e. approximately 50% accuracy.

Using the spectral-spatial resolution accuracy maps showed that a slight spectral degradation actually improved the accuracies in most cases. This is probably due to the fact that a small amount of high frequency noise is present in the ultra-high spectral resolution signatures, which is interfering with the class separation. When these signatures are spectrally degraded, it is akin to passing the signatures through a lowpass filter. Hence, the high frequency noise is attenuated, and the accuracies are increased. Also, by using the spectral-spatial resolution maps, it was shown that relatively high accuracies $\approx 80\%$ could be achieved with a much lower spectral and spatial resolution sensor (FWHM=40nm and 20-40% abundance of the target Cogongrass). This was not expected, and demonstrates the value of this type of resolution analysis.

In conclusion, the information about the achievable accuracies at certain resolutions given in spectral-spatial resolution maps can be used to select or design sensors for various applications. Resolutions can be selected according to needed accuracy, or vice-versa. Resolution maps can also show satellite sensor profile band

coverage, for use in determining primary or alternative sensors to be used for certain applications.

It is recommended that this study be expanded in the future to incorporate temporal resolution. It would be very interesting to see how/if classification accuracies varied with respect to various combinations of spectral, spatial, and temporal resolution.

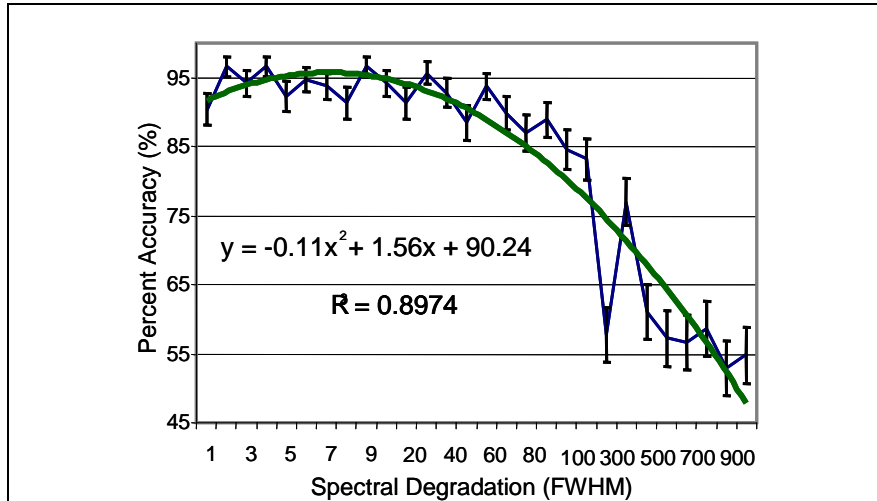

Figure 6. Overall accuracies of ATR when analyzing original and spectrally degraded datasets. Note: no spatial degradation was applied. The error bars indicate 95% confidence intervals, and the green curve results from a regression analysis to determine overall trend of spectral degradation vs. target detection accuracy.

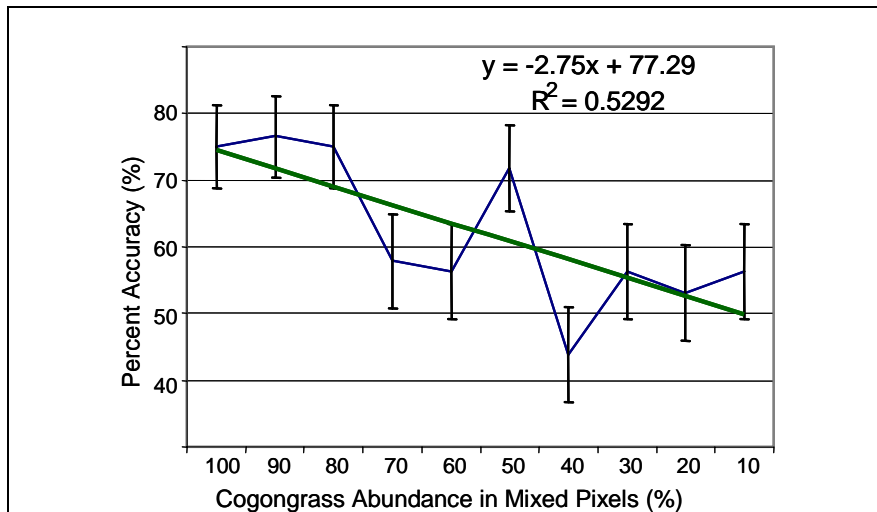

Figure 7. Overall accuracies of ATR when analyzing original and spatially degraded datasets. Note: no spectral degradation was applied. The error bars indicate 95% confidence intervals, and the green curve results from a regression analysis to determine overall trend of spatial degradation vs. target detection accuracy.

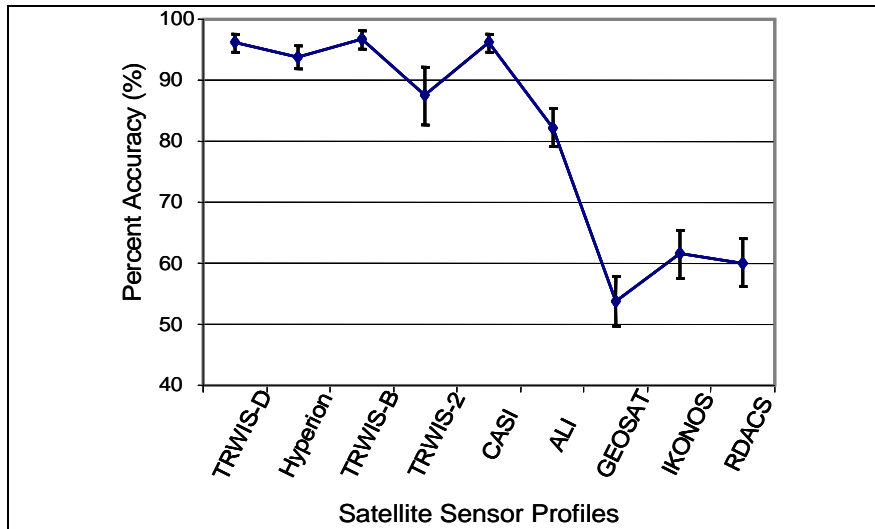

Figure 8. Overall accuracies of ATR when analyzing original and spectrally degraded datasets, where specific sensor profiles have been simulated. Note: no spatial degradation was applied. The error bars indicate 95% confidence intervals.

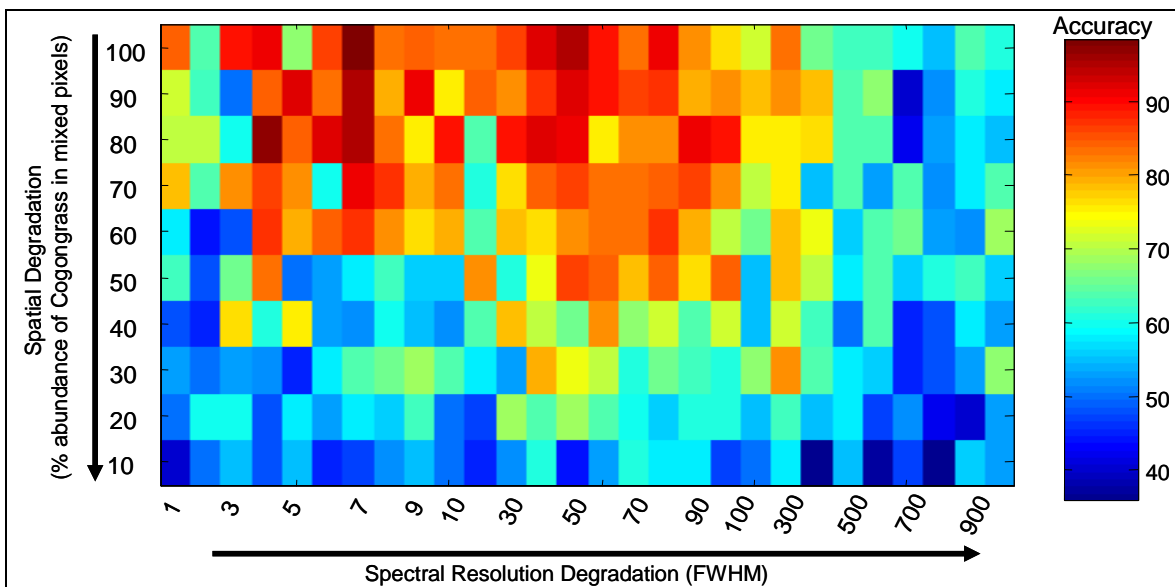

Figure 9. Spectral-spatial resolution accuracy map.

Literature Cited:

L. Bruce, C. Koger, and J. Li, “Dimensionality Reduction of hyperspectral data using discrete wavelet transform feature extraction”, IEEE Transactions on Geoscience and Remote Sensing, vol. 40, issue 10, pp. 2331-2338, Oct. 2002.

J. Byrd, and C.T. Bryson, “Biology, ecology, and control of Cogongrass”, available: <http://www.mdac.state.ms.us/Library/BBC/>

PlantIndustry/PlantPestPrograms/Cogongrass.html. Analytical Spectral Devices
FieldspecPro Spectroradiometer specifications. Available:
http://asdi.com/products_specifications-FSP.asp

R.O. Duda, P.E. Hart, D.G. Stork, Pattern Classification, 2nd ed. New York, NY:
John Wiley & Sons, Inc., 2001.

A. Mathur, L. M. Bruce, J. Byrd, "Discrimination of Subtly Different Vegetative
Species via Hyperspectral Data," Proc. IEEE International Geoscience and Remote
Sensing Symposium, vol. 2, pp. 805 –807, 2002.

A. Mathur, L. M. Bruce, A. M. Cheriyyadat and H. H. Lin, "Hyperspec – Analysis of
Handheld Spectroradiometer Data," Proc. IEEE International Geoscience and
Remote Sensing Symposium, Toulouse, France, July 2003.

R.G. Congalton and K. Green, Assessing the Accuracy of Remotely Sensed Data:
Principles and Practices, Boca Raton: Lewis Publications, 1999.

Task 2.2.1A. Habitat Invasibility Models

PI: Gary Ervin, Co-PI: John Madsen, John Byrd

Collaborators: James Grace, USGS National Wetland Research Center

Introduction

Our work on development of habitat invasibility models was built initially around modeling potential invasion by the federally listed exotic grass, *Imperata cylindrica* (cogongrass). Our initial conceptual model (Figure 2.2.1A-1.) was based on the cumulative expertise of five invasive plant ecologists (Ervin, Madsen, Byrd, with Charles Bryson and Trey Koger, both of USDA-ARS Southern Weed Science Research Unit, Stoneville, MS). It is this model that still will guide our initial development of invasibility models, for aquatic, wetland, and terrestrial plant species.

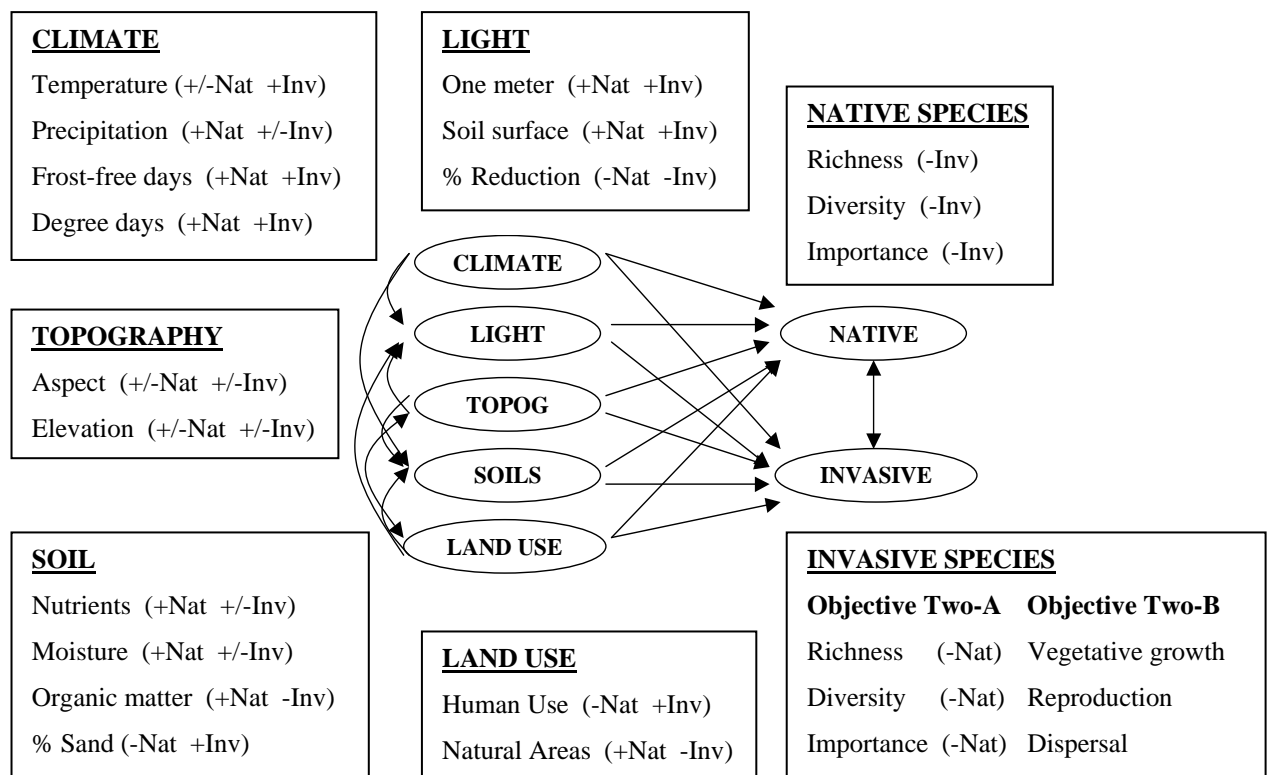

Figure 2.2.1A-1. Hypothesized interactions among variables influencing invasibility of natural areas. Center: General conceptual model (note numbers and directions of arrows vary among direct interactions). Within each outer box, the nature of direct interactions between environmental and biotic variables is indicated within parentheses. For example, “+Nat” indicates a hypothesized positive correlation with Native Species richness, diversity, or relative importance.

Materials and Methods

As described under Task 1.2.1, we have developed a sampling protocol that will be used during the 2006 field season to collect vegetation and habitat data to be used in the implementation of statistical modeling approaches to quantify our hypothesized interrelationships among habitat and vegetation. Points will be located on federal public lands in Mississippi and Alabama, and will be stratified based on the most recent compilation of land use/land cover data for the eastern Gulf Coastal Plain (Southeast Gap Analysis Project). Forty points were selected randomly from within each of the sixteen land cover classes (a total of 640 sample points), across national forests and refuges within the MS and AL portions of the eastern Gulf Coastal Plain.

At each of these points, we will collect data on plant species present and microhabitat characteristics (as per the Beyond NAWMA guidelines [Stohlgren et al. 2003], with the addition of soil analyses), and augment those data with geospatial information, such as climatic data, land use/cover, soil associations, and proximity to such features as urban areas and transportation corridors. Data will be analyzed initially by correlation approaches, including linear and logistic regression. Other modeling approaches may be used, as deemed necessary and appropriate during analyses (e.g., GARP or other statistical approaches).

Literature Cited

Stohlgren, T. J., D. T. Barnett, and S. E. Simonson. 2003. Beyond North American Weed Management Standards. Available at: <http://www.nawma.org/documents/Mapping%20Standards/BEYOND%20NAWMA%20STANDARDS.pdf>

Task 2.2.1B. Habitat Invasibility Models – Physical belowground interaction of *Imperata cylindrica* with native vegetation

PI: Gary Ervin, Co-PI: John Madsen, John Byrd

Collaborators: James Grace, USGS National Wetland Research Center

Introduction

Imperata cylindrica, an invasive C-4 perennial grass, negatively influences native plant communities by forming dense monotypic stands that alter ecosystem properties and lower local species diversity. A hypothesized competitive mechanism by which *Imperata* achieves competitive dominance is a novel use of mechanistic root disturbance (i.e., puncturing) of native vegetation (Photo 2.2.1B-1).



Photo 2.2.1B-1. Rhizome tips of cogongrass (*Imperata cylindrica*) emerging through the soil along a ditch bank on the MSU campus. It has been hypothesized that these sharp rhizomes enhance the competitive ability of cogongrass by damaging neighboring plants and possibly enabling pathogen entry into neighbors.

However, very little empirical evidence is found in the peer-reviewed literature to quantify this phenomenon, much less establish it as a true form of competitive interaction. The present field study was conducted to: (1) quantify the occurrence of inter- and intraspecific rhizome-mediated root penetration and (2) document how this phenomenon is influenced by spatial location.

Materials and Methods

The design to quantify the occurrence of interspecific and intraspecific rhizome-mediated root penetration of vegetation consisted of examining one hundred 0.25-m² plots that were exhumed from the field and returned to the laboratory for analysis. The sods were excavated from the ground to a constant depth of 35 cm and were examined for penetration frequency within two days of sampling (Photos 2.2.1B-2 and 3). The sampling was conducted in a randomized manner on three *Imperata* populations in Oktibbeha County, Mississippi.



Photo 2.2.1B-2. Interspecific rhizome penetration by *Imperata*. The plant being pierced by the cogongrass rhizome is *Paspalum notatum* (bahia grass) and was the most commonly found punctured grass.



Photo 2.2.1B-3. Intraspecific penetration of cogongrass by another cogongrass rhizome. Intraspecific penetrations (cogongrass into cogongrass) accounted for 87% of all rhizome piercing (67 of 77 instances).

Results and Discussion

Results indicated that rhizome-mediated root penetration was more frequently an *intraspecific* phenomenon than *interspecific*. The data also strongly pointed to spatial location as a significant factor, with most penetrations occurring in the interior of established cogongrass stands, as compared to edge plots. Significant correlations of rhizome-mediated root penetrations, as a function of aboveground *Imperata* biomass, were found in the overall analysis of all plots and most strongly in the advancing border of *Imperata* colonies. This work has been submitted to *Weed Biology and Management* for possible publication (Holly and Ervin In Review).

Literature Cited

Holly, D. C. and G. N. Ervin. *In review*. Characterization and Quantitative Assessment of a Potential Rhizome-mediated Root Disturbance Mechanism in Cogongrass (*Imperata cylindrica* (L.) Beauv.). *Weed Biology and Management*.

Task 2.2.2. Terrestrial Plant Virtual Plant Models

PI: John Madsen

Co-PI: John Byrd

Collaborators: David R. Spencer, USDA-ARS, Davis, CA.

Introduction

The relatively new field of plant informatics allows for both the modeling of plant-plant and plant-environment interactions (Room et al., 1994), as well as realistic visualization of “virtual plants” (Room et al., 1996). This technique is already in use in agricultural research to predict weed-crop interactions, create virtual landscapes, and simulating crop plant architecture (Sonohat et al., 2002; Lane and Prusinkiewicz, 2002). We propose to develop a virtual plant model of cogongrass.

Task Description

The development of individual-based three-dimensional models of cogongrass will be scalable from plant-plant interactions to the landscape scale, and aid in the prediction of plant dispersal and growth (Figure 1). In addition, the development of these models will directly contribute to the visualization of invasive plant stands using the technology existing at VAIL. Rather than mathematical projections based on allometric relationships, plant visualizations can be projected from empirical data of plant stands at different life stages. Cogongrass populations will be growth in six tanks. Air and soil temperature will be monitored constantly using Onset HOB0 dataloggers (or comparable), recording temperatures in each trough and in the air at 5-minute intervals.

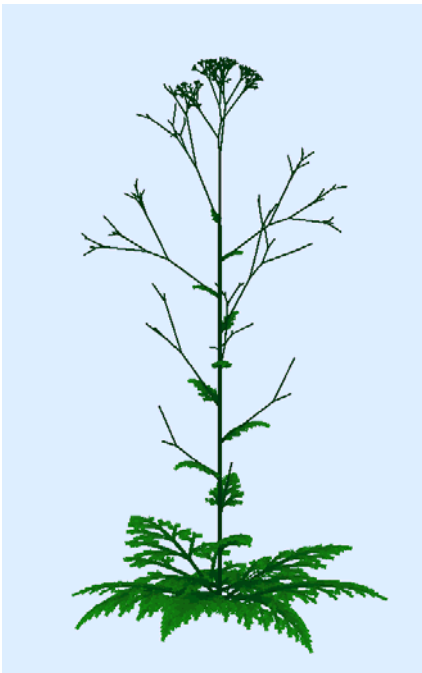

Figure 1. *Parthenium* virtual plant model, developed by the CRC for Tropical Pest Management, Brisbane, Australia. Webpage at: <http://www.biologie.uni-hamburg.de/b-online/virtualplants/ipiimages.html>

Cogongrass (Photo 1) plants will be digitized using a Polhemus Fastrak 3-dimensional digitizer system, utilizing Floradig software (Hanan and Room, 2000). Plants in each tank will be digitized every other week from initiation of growth, beginning in early spring 2006, until the end of the growing season. Digitized plant data will be processed using L-studio, a program that defines virtual plants from digital position data (Prusinkiewicz et al., 2000).



Photo 1. Cogongrass (*Imperata cylindrica*) growing in a Mississippi pasture. Photo by John D. Byrd, Jr.

Literature Cited

Hanan, J. and P. Room. 2000. Floradig User Manual. CSIRO Entomology, Brisbane, Australia. 51pp.

Lane, B. and P. Prusinkiewicz. 2002. Generating spatial distributions for multilevel models of plant communities. Proceedings of Graphics Interface 2002 (Calgary, Alberta, May 27-29, 2002), pp. 69-80.

Prusinkiewicz, P., J.S. Hanan, and R. Mech. 2000. An L-system-based plant modeling language. In: M. Nagl, A. Schurr, and M. Munch (eds.), Application of graph transformations with industrial relevance, Lecture Notes in Computer Science 1779, pp. 395-410, Springer-Verlag, Berlin.

Room, P.M., J.S. Hanan, and P. Prusinkiewicz. 1996. Virtual plants: New perspectives for ecologists, pathologists and agricultural scientists. *Trends in Plant Science* 1:33-38.

Room, P.M., L. Maillette, and J.S. Hanan. 1994. Module and metamer dynamics and virtual plants. *Advances in Ecological Research* 25:105-157.

Sonohat, G., H. Sinoquet, C. Varlet-Grancher, M. Rakocevic, A. Jacquet, J.-C. Simon, and B. Adam. 2002. Leaf dispersion and light partitioning in three-dimensionally digitized tall fescue-white clover mixtures. *Plant, Cell, and Environment* 25:529-538.

Task 2.3. Federal Regulatory Weed Risk Assessment Beach Vitex (*Vitex rotundifolia* L. f.). Assessment Summary

Randy G. Westbrooks and John Madsen. USGS BRD, Whiteville, North Carolina, and Mississippi State University, GeoResources Institute

Abstract

Beach Vitex, a woody vine introduced from Korea in the mid-1980s as an ornamental and dune stabilization plant, has become a serious threat to natural plant and animal communities along the Carolina Coast. It currently occupies 200+ ocean front properties in North Carolina and South Carolina, with a total estimated acreage of about 17 acres. It also occurs in Hawaii. In 2005, a Federal Weed Risk Assessment was conducted to ascertain if Beach Vitex should be listed as a Federal Noxious Weed under the Plant Protection Act of 2000. Beach Vitex was ranked as high in habitat suitability (it is expected to grow in at least five U.S. hardiness zones). It was ranked as high in spread potential after establishment (copious seeding and vegetative runners that are spread by near shore waves and currents). It was ranked as medium in economic importance due to its expected impact on the value and marketing of ocean front properties, as well as federal beach renourishment properties. It was ranked as high in environmental importance due to its documented impacts on native dune vegetation, and degrading of sea turtle habitat. All together, this gives Beach Vitex an Overall Risk Score of High. Since Beach Vitex is already established in the U.S., it was given a Likelihood of Introduction Score of High. The Overall Pest Risk Potential of Beach Vitex Score of High was derived from a combination of the Likelihood and Consequences of Introduction scores.



Photo 1. Beach Vitex in flower.

Based on its high Overall Pest Risk Potential score, and its limited distribution in the United States, it is recommended that Beach Vitex be officially listed as a Federal Noxious Weed. This would prohibit further introductions and interstate movement except under permit. Once it is officially listed, it will automatically be listed as a State Noxious Weed in North Carolina, South Carolina, and a number of other states that automatically listed Federal Noxious Weeds under their state weed laws.

Introduction

Beach Vitex is a woody vine in the Verbena Plant Family that was first introduced from the beaches of Korea to the southeastern United States by scientists at the North Carolina State University Arboretum, in the mid-1980s, as a dune stabilization and ornamental plant. Beginning in the mid-1990s, officials with the Corps of Engineers became concerned about Beach Vitex spreading from large plantings at beach front properties along the South Carolina coast – posing a threat to native dune plants, degrading sea turtle nesting habitat, and impacting multi-million dollar federal beach renourishment projects (T. Socha, Corps of Engineers, Personal Communication, 1996). In 2003, the South Carolina Beach Vitex Task Force, comprised of 16 federal, state, and local agencies, was established to address the problem. To date, the task force has documented about 125 sites planted with Beach Vitex in coastal communities of Horry, Georgetown, and Charleston Counties in South Carolina (averaging 3,000 sq. feet each). In North Carolina, the plant has been documented in beach communities in New Hanover, Pender, and Onslow Counties. Refer to the Task Force Website for an update on efforts to address Beach Vitex (<http://www.beachvitex.org/>).



Photo 2. Beach front property at DeBordieu Beach, Georgetown County, S.C., following Hurricane Ophelia, in the fall of 2005. Three beach vitex plants planted in 1995 on the front dune of this property have formed a monoculture that has totally replaced native sea oats and other native plants. This photo illustrates that no plant, including Beach Vitex can prevent sand dune erosion in extreme storm events.

Based on the native distribution of the plant from Korea and Japan to Malaysia, and Australia, Beach Vitex occupies a very small percentage of its potential ecological range in the United States. However, it is expected that the plant would grow well in coastal communities throughout the southeastern U.S. from Virginia to Florida, and west to Texas.



Photo 3. Dune underwash and erosion around a Beach Vitex planting at DeBordieu Beach, S.C. Summer, 2004.



Photo 4. More dune erosion around a mature Beach Vitex planting at DeBordieu Beach, S.C. December, 2005.

In 2005, the U.S. Geological Survey, National Wetlands Research Center, and the Mississippi State University GeoResources Institute cooperated in conducting a qualitative risk assessment following the USDA APHIS Weed Risk Assessment Process to determine if Beach Vitex should be listed as a Federal Noxious Weed. Under international agreements, a signatory country can only prohibit importation of quarantine pests. A quarantine pest is defined as “a pest of potential economic importance to the area endangered thereby and not yet present there, or present but not widely distributed and being officially controlled”. Federally listed noxious weeds may not be imported into the United States or moved interstate without a special permit. The assessment completes Stages 1 and 2 of the weed risk analysis process as described below.

Materials and Methods

IPPC guidelines describe the three stages in Pest Risk Analysis including Pest Risk Assessment Initiation, Pest Risk Assessment, and Risk Management Planning. Following the APHIS Weed Risk Assessment Template, eight steps were followed in completing stages one and two of the Pest Risk Analysis process, including:

Stage 1 - Initiate the Process. Step 1: Document the Initiating Event; Step 2: Identify previous risk assessments; and Step 3: Establish the identity of the weed.

Stage 2 - Conduct the Assessment. Step 4: Verify quarantine pest status; Step 5: Assess Economic and Environmental Consequences; Step 6: Assess Likelihood of Introduction; Step 7: Determine Pest Risk Potential; and Step 8: Document the Assessment with Literature Citations.

Results and Discussion

Beach Vitex meets the definition of a quarantine significant pest because it is an invasive plant of foreign origin that poses a threat to coastal dune plants and animals communities, could have a negative impact on beach front property values, and currently occupies a fraction of its potential ecological range in the U.S. Currently, it is being controlled by a number of land owners and municipalities along the Carolina Coast. In 2005, rules prohibiting further planting of Beach Vitex on coastal dunes were enacted by the South Carolina Office of Coastal Resource Management. In addition, local ordinances prohibiting further planting of Beach Vitex were passed by a number of municipalities along the Carolina Coast, including Edisto Beach, Folly Beach, and Pawleys Island (South Carolina), as well as Caswell Beach and Baldhead Island (North Carolina).

Summary of Pest Risk Potential Rankings

I. Consequences of Introduction	II. Likelihood of Introduction	III. Pest Risk Potential = (II + III)
A. Habitat Suitability = 3		
B. Spread Potential After Establishment, Dispersal Potential = 3		
C. Economic Impact = 2		
D. Environmental Impact = 3		
CUMULATIVE RISK ELEMENT SCORE = 11 = HIGH (3)	HIGH = 3	HIGH

Scores: High = 3; Medium = 2; Low = 1; Negligible = 0

Based on its native range in the Pacific Rim of eastern Asia, Beach Vitex is expected to grow and reproduce in a minimum of five U.S. hardiness zones. This was the rationale for **ranking it high in habitat suitability**. It was **ranked as high in spread potential after establishment** because it produces copious amounts of seeds, produces runners that grow up to 10 m per year, and it roots at the leaf nodes. Viable stem fragments and seeds are spread along beaches by ocean waves and near shore currents (Task Force Observations). It will also be spread artificially as an ornamental plant unless the plant is regulated. Beach Vitex was **ranked as medium in economic importance** because it is expected to have a negative impact on the value and marketing of infested ocean front properties. There is also concern about the negative impacts of Beach Vitex on multi-million dollar beach renourishment projects that are being conducted to protect such properties. Beach Vitex was **ranked as high in environmental importance** because it forms monocultures that totally crowd out native dune plants [e.g., sea oats (*Uniola paniculata*) and the federally endangered sea beach amaranth (*Amaranthus pumilus*)]. In addition, it degrades sea turtle nesting habitat with dense foliage and impenetrable, wiry roots. All together, this gives Beach Vitex an **Overall Risk Score of High**. Since Beach Vitex is already established in the U.S., it was given a **Likelihood of Introduction Score of High**. The **Overall Pest Risk Potential of Beach Vitex Score of High** was derived from a combination of the Likelihood and Consequences of Introduction scores.

Impact of Listing Beach Vitex as a Federal Noxious Weed

Listing Beach Vitex as a Federal Noxious Weed would prevent further importations of the plant from other countries (except into Hawaii, where it is considered native by some people), and prohibit interstate movement of except under permit. In addition, it would automatically be listed as a State Noxious Weed in certain states, including North and South Carolina (states that automatically list all Federal Noxious Weeds under their own weed laws). This would effectively stop commercial sale of the plant, and provide a strong impetus for eradicating the plant before it has a chance to spread far and wide.

The amount of land infested by Beach Vitex is still incredibly small. To date, about 125 populations (averaging 3,000 sq. feet each) have been documented in South Carolina. If a similar number of populations are found in North Carolina, this would give a total infestation of about *17 acres*.

Literature Cited

Flora of Taiwan, 1978. H. Li, T. Liu, T. Huang, T. Koyama, C. DeVol, Eds. Epoch Publishing Co., Ltd., Taipei, Taiwan, Republic of China. P. 994.

The Flora and Vegetation of Japan. 1974. M. Numata, Ed. Elsevier Scientific Publishing Company, NY. 294 pp.

USDA Plants Database. <http://plants.usda.gov/>

Merrill, E. 1967. An enumeration of Philippine Flowering Plants. A. Asher & Co. Amsterdam. P. 394.

Neal, M. 1965. In the gardens of Hawaii. Bernice P. Bishop Museum. Special Publication #50. Bishop Museum Press. Lancaster, PA. 924 pp.

Wagner, W., D. Herbst, and S. Sohmer. 1999. Manual of the Flowering Plants of Hawaii. Volume 1. University of Hawaii Press. Bishop Museum Press. 988 pp.

Wagner, W., D. Herbst, and S. Shomer. 1999. Manual of the Flowering Plants of Hawaii. Volume 2. University of Hawaii Press. Bishop Museum Press. 1919 pp.

Dry Coastal Ecosystems – Africa, America, Asia and Oceania. 1993. E. van der Maarel, Ed. Elsevier Publishing, Inc., NY. 616 pp.

Gresham, C. and A. Neal. 2004. An evaluation of the invasive potential of beach Vitex (*Vitex rotundifolia*). Bell W. Baruch Institute of Coastal Ecology and Forest Science. Clemson University. Georgetown, S.C. Article in Publication.

Park, C. and E. Park. 2001. Growing characteristics and propagation of *Vitex rotundifolia* for development of rehabilitation plant in seaboard area. Korean J. Env. Eco. 15(1):57-68.

The Flora of Japan. Volume IIIa – Angiospermae, Dicotyledoneae, Sympetalae. 1993. K. Iwatsuki, T. Yamazaki, D. Boufford, and J. Ohba, Eds.

Anonymous. 2004. Kudzu of the Beach threatens Carolina Dunes. Engineer Updates Newsletter. February, 2004. U.S. Army Corps of Engineers. URL: <http://www.hq.usace.army.mil/cepa/pubs/feb04/feb04.htm>

IPPC. (1995). International standards for phytosanitary measures: Principles of plant quarantine as related to international trade (ISPM#1). IPPC & Food and Agriculture Organization of the United Nations. Rome.

IPPC. (1996). International standards for phytosanitary measures: Guidelines for pest risk analysis (ISPM#2). IPPC & Food and Agriculture Organization of the United Nations, Rome.

Task 2.4.A. Cultivation Intensity for Cogongrass Eradication – Integrated Management. Tactics for Control

PI: John Byrd, Plant and Soil Sciences, Mississippi State University

Objective:

Evaluating tillage types and frequencies for cogongrass control

Summary:

The objective of this study is to measure the effectiveness of tillage type and frequency on established cogongrass populations. The three tillage tools used are disk harrow, rotary tiller, and moldboard or bottom plow. Cogongrass foliage was burned prior to tillage. Each tillage tool will be used to thoroughly pulverize the soil surface. Tillage operations will be performed up to three times each year. After first tillage operation, rotary tillage provided the greatest cogongrass reduction; with bottom plow second and disking being the third.

Fig. 1. Burning cogongrass



Fig. 2. 76 days after treatment



Fig. 3. Disked 5/27/05



Fig. 4. 76 days after treatment



Fig 6. Plowed 5/27/05



Fig. 7. 76 days after treatment



Fig. 9. Tilled 5/27/05



Fig. 10. 76 days after treatment



Task 2.4.B. Cultivation Intensity for Cogongrass Eradication – Integrated Management. Tactics for Control

PI: John Byrd, Plant and Soil Sciences, Mississippi State University

Objective:

Evaluating combinations of tillage types and chemical practices for cogongrass control

Summary:

The objective of this study is to measure the effectiveness of tillage combined with herbicide applications for cogongrass control. Three tillage tools; disk harrow, rotary tiller, and bottom plow will be used as the whole plot. Chemical treatments will include glyphosate (Roundup Pro 4L) at 72 fl oz/A , imazapyr (Arsenal 2AS) at 48 fl oz/A + a non-ionic surfactant (NIS) at 0.5% volume per volume (V/V), and a mix of 72 fl oz/A glyphosate and 48 fl oz/A imazapyr. Before any tillage is initiated the aboveground biomass will be removed by burning. At each operation, several passes may be required to thoroughly destroy soil surface. Each tillage practice will be followed by a chemical application on 6 to 8 inch tall cogongrass foliage regrowth. After initial tillage operation rotary tillage offered the greatest amount to biomass production with bottom-plow second and disking third. Chemical applications were made but results are yet to be obtained.

Fig. 1 Rotary Tiller



Fig. 2 Disk



Fig. 3 Bottomplow



Task 3.

Invasive Insects

Task 3.1.A. Early Detection and Reporting of Cactus Moth: Sensory Structures of Larvae

PI: Richard L. Brown, Department of Entomology & Plant Path., Mississippi State University, CO-PI: John Madsen, GeoResources Institute, Mississippi State University, Collaborators: Randy Westbrook, USGS National Wetland Center

Introduction:

Lepidoptera larvae have a variety of sensory structures, or sensillae, that respond to different types of stimuli, including olfactory (or “smell”), gustatory (or “taste”), and tactile. These sensory sensillae are concentrated on the antenna and the mouthparts, especially the maxilla, labium, and labrum, and their functions are related to food seeking and acceptance (Hallberg et al, 2003). The various types of gustatory and olfactory sensillae have pores for detection of chemical molecules: basiconic and thick-walled sensillae are gustatory, whereas styloconic sensillae are olfactory. Tactile sensillae lack pores, and trichoid sensillae are the most common type on larval mouthparts. Although the roles of these sensillae are critical to success of larval development, but they have been poorly studied in Lepidoptera. Descriptions of sensillae have been previously made for only one species of Pyralidae, the Lepidoptera family that includes the exotic cactus moth, *Cactoblastis cactorum*, and native cactus moths in the genus *Melitara* (Schoonhoven and Dethier, 1966).

Materials and Methods:

Larvae of *C. cactorum* and *Melitara prodenialis* were obtained from laboratory colonies maintained by Stephen Hight at the USDA-ARS Center for Biological Control in Tallahassee, Florida. Additional larvae of *C. cactorum* were obtained from infested cactus at Bon Secour National Wildlife Refuge in Alabama. Gerald Baker, Department of Entomology & Plant Pathology, prepared, examined, and photographed larvae. Living larvae were killed and maintained for several weeks in Bouin’s fixative and Bouin-Hollande fixative. Prior to examination with the scanning electron microscope (SEM), larvae were washed in distilled H₂O, placed in detergent for 2-4 hours, sonicated, washed again in H₂O, and placed in 2% osmium tetroxide overnight. Larvae then were washed again in distilled H₂O, dehydrated in graded series of ETOH or acetone, transferred to HMDS, and then air dried. Two heads of each species were stained by crystal violet technique (Slifer, 1960) and examined under light microscopy for presence of pores. Remaining heads of larvae were mounted on aluminum stubs with carbon tape, coated with gold-palladium, and examined with JEOL-JSM6500F SEM.

Results and Discussion:

Sensillae on the antenna, labrum, maxillae, and labium (Fig. 1) of *C. cactorum* and *M. prodenialis* were compared and differences were recorded.

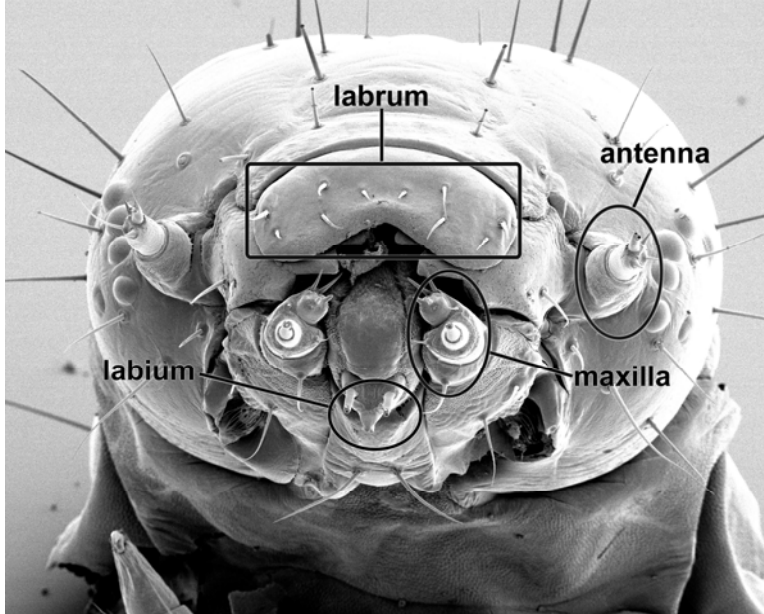

Figure 1. Frontal view of larval head of *Cactoblastis cactorum*.

SEM examinations revealed a new structural organ in both *Cactoblastis* and *Melitara* that is new to science and for which the function is unknown (Fig. 2).

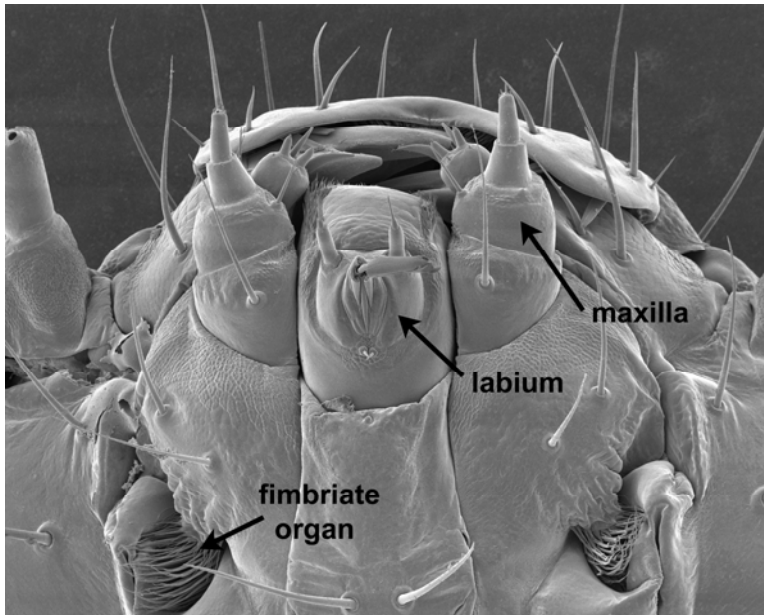

Figure 2. Ventral view of larval head of *Cactoblastis cactorum*.

On the labrum the trichoid sensilla (tactile) of *Cactoblastis* are shorter than those on *Melitara*. The 3-segmented antenna of *Melitara* has two, uniquely shaped, thick-walled sensilla (gustatory), both of which are absent on the antenna of *Cactoblastis*.

The maxillary galea of *Cactoblastis* has two, simple trichodea sensillae (tactile) (Fig. 3), whereas these sensillae each have three forks in *Melitara* (Fig. 4).

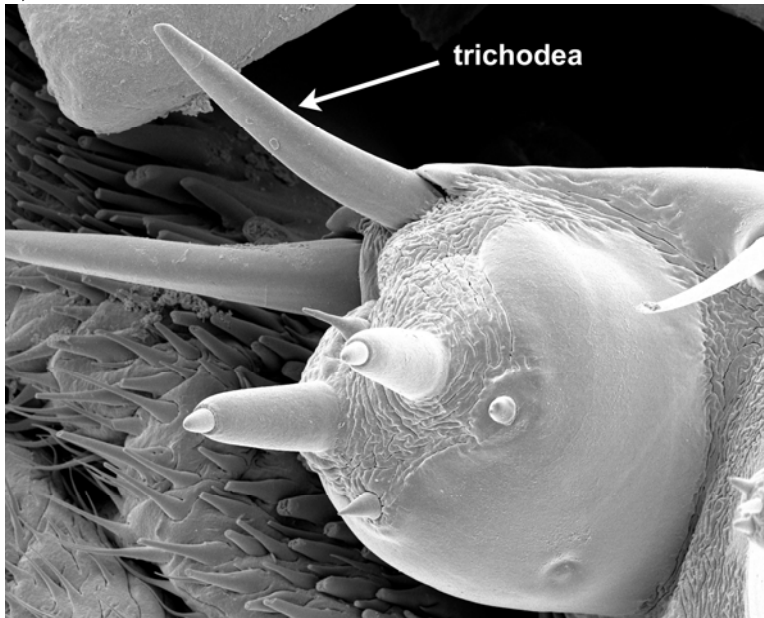

Figure 3. Maxillary galea of *Cactoblastis cactorum*.

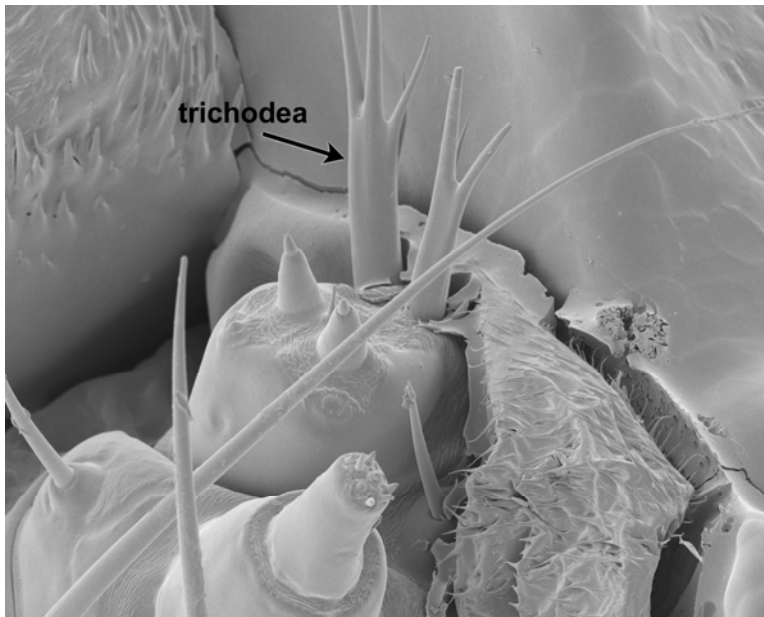

Figure 4. Maxillary galea of *Melitara prodenialis*.

Two styloconic sensilla (olfactory) of similar shape and size are present on the galea of both species. Two basiconic sensilla (gustatory) of similar shape but with different positions are present on the galea of both species. The maxillary palpi of *Cactoblastis* and *Melitara* have the same number of gustatory basiconica, but these differ in their position. The labial palpus has a trichodea sensilla (tactile) and styloconic sensilla (olfactory) that are similar in both species. Examinations of other *Melitara* are needed to determine: 1) if the fimbriate organ is unique to only the two

species examined or if it is present in other cactus feeding species in *Melitara* and related genera, and 2) if all *Melitara* species have similar sensilla that are consistently different from those in *Cactoblastis*. A hypothesis that the fimbriate organ is involved with glandular tissue will be investigated with transmission electron microscope examinations of sectioned heads of additional larvae. If glandular tissue is detected, a second hypothesis that secretions from this organ have anti-microbial activity to reduced decay of the infested cactus cladole will be investigated.

Literature Cited:

Hallberg, E., B.S. Hansson, and C. Löfstedt. 2003. Sensilla and Proprioceptors. Pp. 267-288. In Kristensen, N.P. (ed.). *Lepidoptera, Moths and Butterflies, Vol. 2: Morphology, Physiology, and Development*. Handbuck der Zoologie. Walter de Gruyter, Berlin.

Schoonhoven, L.M. and V.G. Dethier. 1966. Sensory aspects of host-plant discrimination by lepidopterous larvae. *Arch. Neerl. Zool.* 16: 497-530.

Task 3.1.B. Early Detection and Reporting of Cactus Moth: Protocols for Identification of Exotic and Native Cactus Moths

PI: Richard L. Brown, Co-PI: John Madsen

Collaborators: Randy Westbrooks, USGS National Wetland Center

Introduction:

Survey and detection programs for the exotic cactus moth (Pyralidae: *Cactoblastis cactorum*) are dependent on protocols for trapping, identification, and reporting of results. Detection of larvae requires visual inspections and collections from infested cacti, whereas detection of adults currently involves use of an experimental pheromone lure in sticky traps (see Pest Alert, Cactus Moth, *Cactoblastis cactorum* [Joel Floyd, 2005] at: http://www.aphis.usda.gov/ppq/ep/emerging_pests/cactoblastis/). Verifiable identifications of larvae and adults are required to distinguish the exotic cactus moth from native species associated with cactus. At present 21 species in four families of Lepidoptera are known to have larvae associated with *Opuntia* cactus (Neunzig, 1997; Robinson et al, 2002). Of the 15 species of Pyralidae that are associated with *Opuntia*, only the seven species of *Melitara* have been reported as feeding inside cladodes, although habits of some other species are poorly known. Adults of *Cactoblastis* and *Melitara* are superficially similar in wing color and pattern, and their identification requires examination of male genitalia. Identification of adults in pheromone traps has also been problematic because the experimental lure attracts species of *Melitara* as well as other species of Lepidoptera. Published descriptions of *Melitara* larvae are based on microscopic characters in preserved specimens, especially chaetotaxy, rather than color or other diagnostic character that can be used by survey personnel in the field. The objectives of this task were the following: 1) develop protocols for identifying adults of cactus moths in pheromone traps, and 2) develop protocols for identifying larvae infesting cladodes of *Opuntia* cactus. These objectives required: 1) examination of pheromone traps operated in states from Alabama west to California to determine which species of Lepidoptera were attracted to the cactus moth pheromone lure and which species might be confused with the cactus moth, and 2) collection and rearing of larvae infesting *Opuntia* cladodes in western U.S. to obtain diagnostic characters for distinguishing larvae of the exotic cactus moth from larvae of native species.

Materials and Methods:

Placement and operation of pheromone traps in Alabama, Mississippi, Louisiana, Texas, New Mexico, Arizona, and California were coordinated by Stephen Hight, USDA-ARS Center for Biological Control in Tallahassee, Florida. Traps were operated by personnel in national parks and wildlife refuges in Alabama (Bon Secour National Wildlife Refuge), Mississippi (Grand Bay Savannah National Wildlife Refuge and Gulf Islands National Seashore), and Texas (Padre Island National Seashore). Other traps were operated by personnel of USDA-APHIS and

CAPS (Cooperative Agricultural Pest Survey) in Alabama, Louisiana, New Mexico, Arizona, and California. Depending on the state and impact of hurricanes, traps were operated during a period from May through November. All trap samples were mailed to Richard Brown for identification, and results of all trap samples were reported to Stephen Hight. Trap samples from national parks and wildlife refuges were additionally reported to the GRI Cactus Moth Detection and Monitoring Network. Results of trap samples operated by APHIS and CAPS personnel will be reported in the future. All moths from traps operated in Alabama, Mississippi, Louisiana, and Texas were identified to genus or species and counted. Moths from New Mexico, Arizona, and California that were similar in size to *Cactoblastis* were identified to species when possible, but no attempt was made to identify the small sized moths below family level. Because small Pyralidae dominated the trap catches in these western states, counts were estimated by counting number of specimens in three rows of squares (both ends and middle), multiplying by three to account for the nine rows, and rounding the number to nearest five (Photo 1).



Photo 1. Pheromone trap with moths trapped during one week in Arizona with arrows indicating rows of squares that were used for counting numbers of specimens.

Collections of larvae infesting *Opuntia* in Arizona and New Mexico were made by Todd Gilligan, graduate student at Ohio State University. All cacti suspected to be infested by larvae were photographed for subsequent identification by Victor Maddox, and infested or damaged cladodes were shipped to Richard Brown for rearing and identification. Cladodes with signs of damage or infestation were dissected at Mississippi State University to determine if larvae were present. Detected larvae in cladodes were removed for photography, after which they were returned to the cladole they had infested to complete development. Pupated larvae will be held over the winter to break diapause and to obtain emergence of moths for identification in 2006.

Results and Discussion:

Surveys in seven states involved use of 95 cactus moth pheromone traps resulting in 365 samples that have been identified and counted to date (approximately 40 samples remain to be identified). These traps yielded 11,385 moths, of which most were small pyralids collected in Arizona and California. Thirty-six species in various families of moths have been identified from the pheromone traps. Sixteen *Cactoblastis cactorum* moths were collected in traps operated at Bon Secour National Wildlife Refuge (Fort Morgan) between May 17 and August 16, 2005.

Larvae of four native species of cactus moths have been reared and photographed. These include *Melitara prodenialis* in eastern U.S. (Photo 2) and three unidentified species of *Melitara* in Arizona and New Mexico (Photos 3-5). Larvae of these native species are easily distinguished from those of *Cactoblastis cactorum* by their color.



Photo 2. Larva of *Melitara prodenialis* (Florida; courtesy of Stephen Hight)



Photo 3. Larva of *Melitara* "sp. 1" from Arizona.



Photo 4. Larva of *Melitara* "sp. 2" from Arizona.



Photo 5. Larva of *Melitara* "sp. 3" from New Mexico.

Literature Cited:

Neunzig, H. H. 1997. Pyraloidea, Pyralidae (Part). In Dominick, R. B., et al., The Moths of America North of Mexico, fasc. 15.4. Allen Press, Lawrence, KS. 157 pp.

Robinson, G.S., P.R. Ackery, I. J. Kitching, G.W. Beccaloni, and L.M. Hernández. 2002. Hostplants of the Moth and Butterfly Caterpillars of America North of Mexico. American Entomological Institute, Gainesville, FL. 824 pp.

Task 3.2.A. Distribution of *Opuntia* in the Region

PI: John Madsen, Co-PI: Victor Maddox, Gary Ervin, John Byrd, Richard Brown,
Collaborators: Randy Westbrook

Introduction:

The Genus *Opuntia*, also known as pricklypear, is in the Family Cactaceae. *Opuntia* is the most widespread genus of cactus and one of the largest with 181 species. There are over 50 native species in the United States and many more in cultivation. *Opuntia* are generally thought of as plants of the dry landscape of the Southwestern U.S. However, native *Opuntia* can be found in almost every state and there are rare species of *Opuntia* in the Southwest, as well as Florida.

Pricklypear cacti are being threatened by the accidental introduction of the cactus moth (*Cactoblastis cactorum*) into Florida. It is native to Argentina and since introduction it has expanded its range to Dauphin Island, Alabama on the Gulf Coast and Charleston, South Carolina on the Atlantic Coast. The caterpillars of this moth are capable of complete destruction of entire plants and stands of cacti. This exotic pest is expected to have a catastrophic effect on the landscape of the western states and Mexico, if its range expands beyond Louisiana. Since all *Platyopuntia* are potential hosts for the cactus moth, many ornamental species of pricklypear are also at risk.

Materials and Methods:

Nomenclature. The Genus *Opuntia* has undergone a considerable amount of revision. Scientific names for native *Opuntia* in the web database are closely consistent with the USDA-NRCS Plants Database at:

<http://plants.usda.gov/index.html> and/or the Flora of North America at: http://www.efloras.org/florataxon.aspx?flora_id=1&taxon_id=10141. Scientific names for non-native ornamental *Opuntia* are consistent with Anderson (2001).

Voucher specimens were collected mostly from natural *Opuntia* populations. These were split, salted, dried, and mounted on 100% cotton for future reference. All *Opuntia* associate species placed in the database drop-down are consistent with the Integrated Taxonomic Information System at <http://www.itis.usda.gov/>.

Mapping. Much of this project has involved mapping *Opuntia* populations, field data acquisition, and web database entry. From ground reconnaissance, most *Opuntia* population GPS coordinates were determined by, and stored in, a Garmin 276C (Garmin International, Inc., Olathe, KS 66062) and later downloaded to MapSource (Garmin International, Inc., Olathe, KS 66062) software. Other state maps and gazetteers were used in the field. Waypoints were saved to Microsoft Excel (Microsoft Corp.) and checked at <http://boulter.com/gps/> for additional information which could be added to hard data forms before database entry.

Results and Discussion:

Data Forms. One of the first goals of this project was to develop a set of data forms, acceptable to MSU-GRI, USGS, and USDA, for entering information about the cactus moth and host plants. Forms developed were the Pricklypear Data Form

(CMPP0405), Cactus Moth Visual Observation Data Form (CMVIS0405), and Cactus Moth Trap Data Form (CMTRAP0405). In April 2005, forms were made available on the web database at http://www.gri.msstate.edu/cactus_moth/. Descriptions for form data variables (CMPPVD0405, CMVISVD0405, and CMTRAPVD0405) were also provided via the database. Pricklypear Data Forms were used during mapping.

Drop-down lists of *Opuntia* species (*Platyopuntia*) for each state were developed and NAPIS codes were assigned by USDA for each *Opuntia* species. A drop-down list was developed for *Opuntia* associate species, which will be updated periodically.

Pricklypear Species and Distribution. A considerable amount of mapping and databasing was conducted in 2005. Once data forms were developed, data collection was initiated. As of 18 Nov., 706 completed Pricklypear Data Forms had been entered into the database and another 145 Pricklypear Data Forms entered into the incomplete system. *Opuntia* mapping was conducted in Alabama, Arkansas, Florida, Georgia, Louisiana, Mississippi, Missouri, North Carolina, South Carolina, Tennessee, and Texas. The movement of cactus moth has moved as far west as Dauphin Island, AL has prompted extensive mapping in Mississippi. As of 30 November 2005, *Opuntia* was identified in approximately 73 percent of the counties in Mississippi (82 counties total). Gulf and Atlantic coast areas received the most intensive mapping.

To date, native pricklypear identified are devil's-tongue (*Opuntia humifusa*) (Fig. 1), cockspur pricklypear (*O. pusilla*) (Fig. 2), erect pricklypear (*O. stricta*) (Fig. 3), and semaphore cactus [*Consolea corallicola* (Syn. *Opuntia corallicola*)]. Devil's-tongue has the widest distribution, followed in order by cockspur pricklypear, erect pricklypear and semaphore cactus.



Fig. 1. Devil's-tongue (*Opuntia humifusa*) with fruit.



Fig. 2. Cockspear pricklypear (*Opuntia pusilla*) with red fruit.



Fig. 3. Erect pricklypear (*Opuntia stricta*) with fruit.

Ornamental *Opuntia* species were also mapped. *Opuntia ficus-indica* (Fig. 4) was by far the most common species identified in cultivation. Other ornamental *Opuntia* identified include *O. aciculata*, *O. cochenillifera*, *O. ellisiana*, *O. engelmannii* var. *engelmannii*, *O. engelmannii* var. *linquiformis*, *O. humifusa*, *O. macrorhiza*, and *O. undulata*. Not all ornamental pricklypear identified during mapping belonged to the Subgenus *Playopuntia*. The Subgenera *Cylindropuntia* and *Consolea* were also identified. These included *Cylindropuntia imbricata* and *Consolea corallicola*. The fact that *Opuntia* were identified in 75 percent of the counties in Mississippi illustrates an extensive distribution. Is it highly probable that *Opuntia* populations exist in every county. Mississippi as an example, this may also imply that there are still many *Opuntia* populations unmapped in other states.



Fig. 4. Tuna cactus (*Opuntia ficus-indica*) with fruit.

Sentinel Sites. To date, there are 5 sentinel sites in Mississippi, 8 sentinel sites in North Carolina, and 14 sentinel sites in South Carolina. More are pending in Mississippi. Although additional mapping is needed, the establishment of a line of sentinel sites in front of the cactus moth leading edge is a current priority. In Mississippi, Grand Bay NERR and TNC's Deaton Reserve have agreed to establish sentinel sites. Hurricane Katrina hampered sentinel site efforts in Mississippi.

Master Gardener Volunteers. A workshop on cactus moth was hosted for Master Gardeners with approximately 65 master gardeners in attendance representing 24 county extension programs. Aside from potential master gardener volunteers, 15 master gardeners volunteered to serve as Cactus Moth County Coordinators. These individuals have the ability to enter *Opuntia* and cactus moth data into the database. Two press releases were sent to county coordinators. Some volunteers have already reported *Opuntia* populations. A volunteer County Coordinator in coastal MS has assisted BJ Lewis (USDA) with locating *Opuntia* populations and establishing trap locations.

A great deal of was spent on public and agency awareness. Press releases, workshop activities, and garden and patio show information were oriented toward public awareness and involvement. An email was sent to county extension offices in Mississippi requesting information on *Opuntia* populations. Information on cactus moth and *Opuntia* are accessible via the web database, or as flyers. Although Master Gardeners in Mississippi have been involved with the project, there is a need to collaborate with the National Garden Clubs of America. This collaborative effort will assist with locating *Opuntia* populations from many states and may provide volunteers in strategic areas.

In conclusion, considerable progress was in 2005, and in time, this may become the most comprehensive database on *Opuntia* populations. Knowing the potential movement of the cactus moth via the hosts will play an important role in preventing its impact upon the S.W. United States and Mexico. Increased public

and agency involvement and the establishment additional sentinel sites are important priorities for the coming year.

Literature Cited:

Anderson, Edward. 2001. The cactus family. Timber Press, Portland, OR.

Task 3.2.B. Distribution of *Opuntia* in the Region – Morphological and genetic analyses of a putative *Opuntia* hybrid

PI: John Madsen, Co-PI: Victor Maddox, Gary Ervin, John Byrd, Richard Brown
Collaborators: Randy Westbrook, USGS National Wetland Research Center

Introduction:

Opuntia species can exhibit high degrees of morphological variation that can make interspecific delimitations problematic (Benson, 1982; Labra et al., 2003; Pinkava et al., 1977; Pinkava and Parfitt, 1982; Pinkava et al., 1992; Rebman and Pinkava, 2001). Also, *Opuntia* species are known to be prolific hybridizers which can further complicate the ability to separate species morphologically (Benson, 1982; Grant and Grant, 1979; Griffith, 2003 and 2004; Rebman and Pinkava, 2001). During field surveys, several different populations of *Opuntia* have been found that seem to exhibit an intermediate growth form between the two species *Opuntia humifusa* (Raf.) Raf. and *Opuntia pusilla* (Haw.) Nutt. It is proposed that these populations could represent hybrid forms of the combination of the two species. The detection of hybrid populations is being attempted using morphological and molecular analyses.

Materials and Methods:

To better understand habitat preferences for *Opuntia* species within the southeast United States, ninety-five 1m² plots covering sixteen sites were surveyed in Mississippi and Alabama (see Task 3.3). Along with vegetation community and abiotic data, morphological data also were taken. Mature cladodes from one plant per plot were randomly chosen for measurement; thus, no growing cladodes or spines were measured. The length (L), thickness (T) and width (W) of each cladode for up to three segment lengths were measured. The apical spines (up to four areoles per cladode) were measured in length. These data were compared for the between species variation of *O. pusilla*, *O. humifusa*, and the putative hybrid.

In progress are fruit size determinations for the different species, where fruit from ten different plants within a population were collected and measured. The seed sizes and morphology also will be measured. These data also will be compared among the different species and putative hybrid.

For extracting DNA for molecular analysis, the CTAB extraction method will be used. This method helps to alleviate the complications of large amounts of polysaccharides that bind to the DNA molecules and reduce the amount of usable material for DNA sequencing or other analyses (de la Cruz et al., 1997; Griffith and Porter, 2003; Mondragon-Jacobo et al., 2000; Tel-Zur et al., 1999; Wallace, 1995). After DNA extraction, there are various methods that can be employed to infer genetic relationships among *Opuntia* (e.g., sequence data, RAPD analysis, AFLP markers, microsatellite data; Labra et al., 2003), however, the author is still in the process of researching the appropriate method for deducing species and possibly hybrid relationships.

Also, in order to understand differences in morphology, specimens from each *Opuntia* site have been collected and planted in a greenhouse setting to form a “living herbarium.” Specimens from all of these locations have been added to the Mississippi State Herbarium (MISSA) as voucher specimens as well to provide locality data and reference material on all of the sites studied. The living herbarium contains all of the naturally occurring species of *Opuntia* in Mississippi and Alabama. It covers 39 sites and 23 counties among the two states. Also, the living herbarium includes collections from Georgia, Florida and South Carolina. In total, 117 plants are now being grown in the greenhouse (Photo 3.2B-1).



Photo 3.2B-1. The Greenhouse setting composed of 3 tables for different species’ segregations and a fourth table for demonstrative purposes.

This material also serves as a living resource for molecular testing; if more material is needed for analysis, everything necessary is readily available. This diminishes the amount of disturbance on natural populations and the amount of travel for resampling previously surveyed populations.

Results and Discussion:

Morphological measurements revealed that *O. humifusa* and the putative hybrid were more similar than either was with *O. pusilla*. Average cladode lengths for *O. humifusa* and the hybrid were 7-9cm. The average width and thickness of cladodes was 5-6cm and 0.9-1cm respectively. Average spines lengths were 2.5-2.6cm for primary spines and 1.5-1.8cm for secondary spines. *Opuntia pusilla* had an average cladode L-W-T ratio of 3.9-2.3-0.9cm. Average primary spines were 2.2cm, and secondary spines were an average of 1.3cm in length. Out of the populations surveyed, only *O. pusilla* and the hybrid had tertiary spines, those averaging 1.2 and 1.5cm respectively.

Those specimens planted in the greenhouse also have been monitored, and interesting results have been observed. Spine lengths among those specimens generally are longer than plants within natural populations. Spine production also

seems to be increased (Photo 3.2B-2). Mature cladodes have been observed growing new spines. In some cases up to four spines have been produced from one areole in *O. pusilla*. Also, some *O. humifusa* specimens that came from spine-free populations have grown spines under greenhouse conditions. Nobel (1983) states that spines serve as long-wave (infrared) radiators, thereby reducing the body temperature of the plant. Thus, increased spine production could be a product of the high temperatures recorded within the greenhouse. Daytime temperatures, in some cases, reached as high as 50°C.



Photos 3.2B-2. The increase of spine production and increased spine lengths of *O. pusilla* from Smith Co., MS.

A lack of new cladode growth also was seen in the greenhouse. This could be due to increased heat loads as well. Spine production has been shown to decrease overall plant production in some cacti by reducing the amount of PAR absorbed by stem areas. This decreases the amount of CO₂ uptake and nocturnal acid accumulation; therefore, it reduces photosynthetic rates. High nighttime

temperatures have been shown to cause stomatal closures which would also lead to a decrease in the photosynthetic rates of a plant exhibiting crassulacean acid metabolism (CAM; Nobel, 1983). Reduced growth rates were observed in the field as well during the hotter time periods of the summer.

An experiment to test the induction of spines due to temperature increase will be conducted. *Opuntia pusilla* will be observed under different shade treatments in the greenhouse. This hopefully will provide more insight on the phenological plasticity exhibited by *Opuntia* species.

Literature Cited:

Benson, L. 1982. The Cacti of the United States and Canada. Stanford University Press, Standford , CA. 1044 pp.

De la Cruz, M., Ramirez, F., and Hector Hernandez. 1997. DNA isolation and amplification from cacti. *Plant Molecular Biology Reporter* 15(4):319-326

Grant, V. and Karen Grant. 1979. Hybridization and variation in the *Opuntia phaeacantha* group in central Texas. *Botanical Gazette* 140(2):208-215

Griffith, M.P. and J. Mark Porter. 2003. Back to the basics: a simple method of DNA extraction for mucilaginous cacti. *Bradleya* 21:126-128

Griffith, M.P. 2003. Using molecular evidence to elucidate reticulate evolution in *Opuntia* (Cactaceae). *Madroño* 50(3):162-169

Griffith, M.P. 2004. The origins of an important cactus crop, *Opuntia ficus-indica* (Cactaceae):new molecular evidence. *American Journal of Botany* 91(11):1915-1921

Labra, M., Grassi, F., Bardini, M., Imazio, S., Guiggi, A., Citterio, S., Banfi, E., and S. Sgorbati. 2003. Genetic relationships in *Opuntia* Mill. Genus (Cactaceae) detected by molecular marker. *Plant Science* 165:1129-1136

Mondragon-Jacobo, C., Doudareva, N., and Bruce P. Bordelon. 2000. DNA extraction from several cacti. *HortScience* 35(6):1124-1126

Nobel, P.S. 1983. Spine influences on PAR interception, stem temperature, and nocturnal acid accumulation by cacti. *Plant, Cell and Environment* 6:153-159

Pinkava, D.J. and Bruce D. Parfitt. 1982. Chromosome numbers in some cacti of western North America. IV. *Bulletin of the Torrey Botanical Club* 109(2):121-128

Pinkava, D.J., Parfitt, B.D., Baker, M., and Richard D. Worthington. 1992. Chromosome numbers in some cacti of Western North America-VI, with nomenclatural changes. *Madroño* 39(2):98-113

Pinkava, D.J., McGill, L.A., and Timothy Reeves. 1977. Chromosome numbers in some cacti of western North America-III. *Bulletin of the Torrey Botanical Club* 104(2):105-110

Rebman, J.P., and D.J. Pinkava. 2001. *Opuntia* cacti of North America-An overview. *Florida Entomologist* 84(4):474-483

Tel-Zur, N., Abbo, S., Myslabodski, D., and Y. Mizrahi. 1999. Modified CTAB procedure for DNA isolation from Epiphytic cacti of the genera *Hylocereus* and *Selenicereus* (Cactaceae). *Plant Molecular Biology Reporter* 17:249-254

Wallace, R.S. 1995. Molecular systematic study of the Cactaceae: Using chloroplast DNA variations to elucidate Cactus phylogeny. *Bradleya* 13:1-12

Task 3.3. *Opuntia* Habitat Models

PI: Gary Ervin, Co-PI: John Madsen, John Byrd

Collaborators: James Grace, USGS National Wetland Research Center

Introduction:

Due to the relatively recent detection of the invasive cactus moth, *Cactoblastis cactorum* in the southeast United States, and its proposed, continual westward spread through the coastal states (Hight et al., 2002; Soberon et al., 2001), it is imperative that we understand habitat associations of *Opuntia* species, the host plants of cactus moth. *Cactoblastis* is known to affect all three *Opuntia* species found naturally in the mid-south US: *Opuntia humifusa* (Raf.) Raf., *Opuntia pusilla* (Haw.) Nutt., and *Opuntia stricta* (Haw.) Haw. (Hight et al., 2002). However, *O. stricta* is generally restricted to coastal areas (Benson, 1982), except for inland introductions as a landscape ornamental. Therefore, habitat typifications for *Opuntia* species have been limited to *O. pusilla* and *O. humifusa* (Photos 3.3-1 and 2), which commonly are found inland. Descriptive habitat data consisted of abiotic data such as pH and soil particle size determinations, and biotic data such as floral community structure.



Photo 3.3-1. *O. pusilla* from Deaton Preserve; Greene Co., MS.

Materials and Methods:

Sixteen sites were chosen from previously surveyed areas where *Opuntia* species were known to grow. Seven sites were of *O. humifusa* and seven were for *O. pusilla*. The other two sites were for a putative hybrid between *O. humifusa* and *O. pusilla* (Photo 3.3-3). These were chosen from a variety of physiographic regions in the states of Mississippi and Alabama to encompass a large degree of heterogeneity that could possibly exist among study sites. A systematic random sampling method was applied at each site to record plant species present and their percent cover, take soil samples (at a depth of 15cm using a soil corer), and make measurements on *Opuntia* for later use in morphological comparisons (Photo 3.3-2). The number of 1m² plots used at each site was subjectively determined depending on the amount of available survey area. Typically, *Opuntia*

populations seen in the field encompassed relatively small areas, thus few plots usually could be incorporated into a given survey area. A total of 95 plots were used for all sixteen sites.



Photo 3.3-2. Putative hybrid from Newton Co., MS.



Photo 3.3-3. 1m² plot from a site containing *O. humifusa*; Forrest Co., MS.

Plant composition, percent cover data, and abiotic data were analyzed using PCOrd 4.27 for Windows (MjM Software). Indicator species analysis (ISA) was used to determine if any species found within and among sites were specific to a certain *Opuntia* species' habitat or if there were species typically found in all sites. A Monte Carlo test of significance was used to determine what species would significantly be associated with different *Opuntia* species after 1000 permutations at $p < 0.05$. Multi-response permutation procedure (MRPP) was used to elucidate relationships between species composition, *Opuntia* cover and the abiotic variables that were measured (pH and soil particle size).

Soil particle size was determined using the hydrometer method (Foth, 1990), and soil pH was determined using a handheld pH meter (EXTECH instruments; ExStik pH Meter). Logistic regression was used on presence-absence data for each species, and the putative hybrid, to determine which of the measured soil parameters was most closely associated with each species.

Results and Discussion:

From the 95 plots, a total of 179 plant species were found associated with *Opuntia*. *Opuntia humifusa* and *O. pusilla* sites had the highest pH values with an average of 5.13 and 5.79 respectively. The average pH for the hybrid was 3.7. The average sand content for soils was >83% for all species. Clay content was highest in *O. humifusa* sites and lowest in *O. pusilla* locations. The percent silt content showed the same tendency, with the hybrid population averages being between the other two species. Estimated probability of occurrence of each species, based on correlations with soil parameters determined through logistic regression, supported these trends (Figure 3.3-1). The average percent cover per plot by different *Opuntia* species was greatest among *O. humifusa* and lowest within *O. pusilla* plots.

Figure 3.3-1. Results of logistic regression analyses of *Opuntia* soil “preferences.” Data were collected from ninety-five plots, at sixteen sites in Mississippi. Graphs for *O. pusilla* indicate the estimated probability of occurrence as affected by the indicated variable, in the context of observed values of the other soil parameter. For example, the upper right panel indicates the log relationship between soil % clay and *O. pusilla*, at the observed levels of soil pH for the study plots. This graphical approach was taken because the best model (as determined by corrected AIC differences) included effects of both soil clay composition and pH, thus estimated probabilities must account for realistic combinations of both factors.

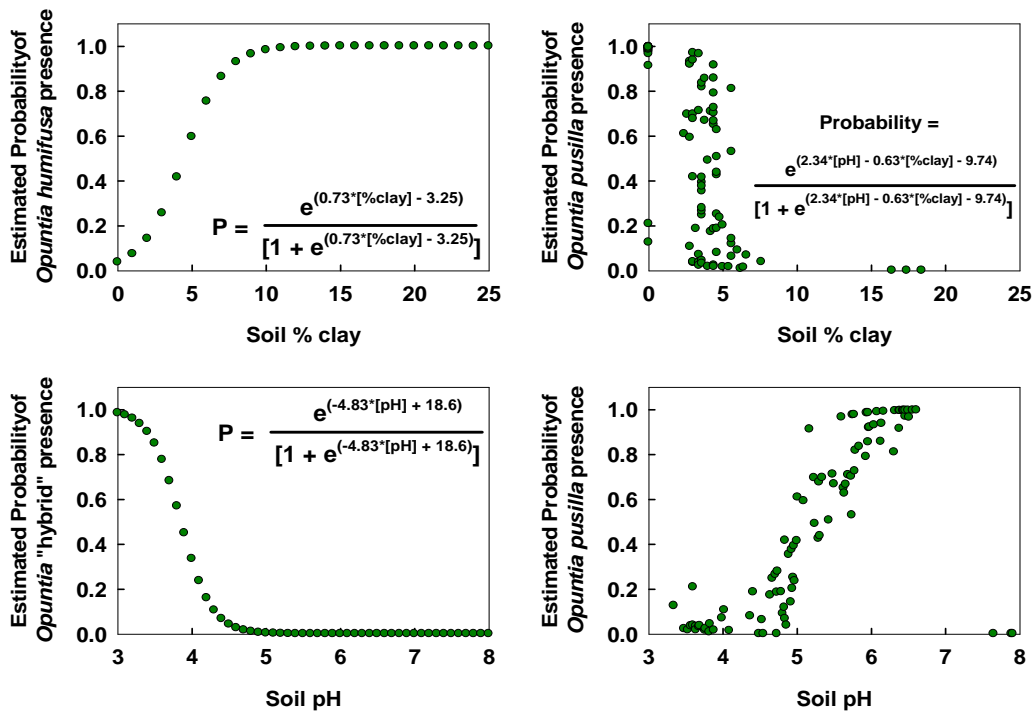

Four plant species were found to be significantly correlated with *O. humifusa*. Ten species correlated well with the sites containing *O. pusilla*, and twelve species were found to be highly associated with the putative hybrid. Results from the MRPP analysis showed a high correlation between all three site types based on different *Opuntia* species and abiotic variables with all p-values < 0.0001. Thirty-one species were found to be high in relative abundance between at least two species of *Opuntia*. Thirteen species were found to be common among all three species.

Although 179 different species were found among all of the 95 plots, only 17% of those species were highly associated with at least two of the *Opuntia* species investigated. This demonstrates the degree of habitat heterogeneity that can be seen within populations of *Opuntia* in the mid-south. Out of the four indicator species for *O. humifusa*, three were non-native to the mid-south. This probably results from the moderate levels of disturbance needed in some cases to keep canopies open for the continued, successful growth of *Opuntia*. The average pH levels were similar between *O. pusilla* and *O. humifusa*, but pH in the soils from plots with the putative hybrid was much lower. This could be an artifact of lower sampling numbers of hybrid populations, or it could have other implications, if it holds to be true among other hybrid populations. Lower pH levels themselves could affect the morphology of *Opuntia* and cause the supposed intermediate growth form between the two species. On the other hand, these populations could represent a true hybrid between *O. pusilla* and *O. humifusa* that requires markedly different soil characteristics.

Because of the restricted sampling area in these studies, further analyses will be necessary to determine the complexities of these systems and to delimit relationships between *Opuntia* species and their biotic and abiotic habitat. *Opuntia humifusa* and *O. pusilla* are sympatric in some instances and could therefore survive equally well under the same environmental influences. This could simplify attempts at modeling habitat requirements – or add a layer of complexity if they are found to be ecological widespread in the region and associated with diverse other species. Further efforts along these lines will include habitat modeling as described under Tasks 1.2.1 and 2.2.1.

Literature Cited:

- Benson, L. 1982. The Cacti of the United States and Canada. Stanford University Press, Stanford, CA. 1044 pp.
- Foth, H.D. 1990. Fundamentals of Soil Science. John Wiley & Sons, Inc. New York, NY. 360 pp.
- Hight, S.D., Carpenter, K.A., Bloem, K.A., Pemberton, R.W., and P. Stiling. 2002. Expanding Geographical Range of *Cactoblastis cactorum* (Lepidoptera: Pyralidae) in North America. *Florida Entomologist* 85(3):527-529
- Soberon, J., Golubov, J., and J. Sarukhan. 2001. The importance of *Opuntia* in Mexico and routes of invasion and impact of *Cactoblastis cactorum* (Lepidoptera:Pyralidae). *Florida Entomologist* 84(4):486-492

Task 3.4. Optimization of a nutria spatial model

PI: John Madsen, Co-PI: James Fowler, Collaborator: Jacoby Carter, National Wetland Research Center

We examined the original `Run_Nutria_model.m` code and observed that the main processing of the model was essentially divided into three passes through the model grid: 1) a relatively short pass that totals certain values across the grid ("Process Totals"), 2) a lengthy pass that updates each cell's values from one timestep to the next ("Process Cells"), and 3) a pass that diffuses values between cells as called in the separate `Diffusion1.m` ("Diffusion"). We measured the CPU time for each of these as follows:

Process Totals: 0.0228 sec/timestep
Process Cells: 0.1733 sec/timestep
Diffusion: 1.3400 sec/timestep

These times are in seconds as averaged over 40 timesteps for the model running on a 3-processor Xeon 3GHz with 1.5 GB RAM. The model is set up for a 9x11 grid with default values and plotting updates disabled.

The "Process Totals" and "Process Cells" passes would possibly be amenable to a parallelized implementation on a cluster as both passes process each cell independently. However, the "Diffusion" pass, involving communication between cells, cannot be parallelized. Since the "Diffusion" pass is by far the most computationally expensive component of the model, it was decided to explore possible code speedups other than implementation on a cluster.

In examination of the `Run_Nutria_Model.m` and `Diffusion1.m` code, it was observed that there was extensive use of Matlab's cell arrays for data structures. A more efficient implementation would use multidimensional matrices instead, since cell-array processing cannot be vectorized in Matlab and thus requires the use of notoriously slow "for" loops. On the other hand, Matlab is designed for, and excels at, vectorized processing on matrices and multidimensional matrices.

Consequently, we have completely restructured the model data structures in `Run_Nutria_Model.m` and `Diffusion1.m` to exploit multidimensional matrices to the greatest extent possible. We then started vectorizing the three main processing passes in `Run_Nutria_Model.m`. At this point, we have successfully vectorized the "Diffusion" and the relatively short "Process Totals" passes. Vectorization of the "Process Cells" pass, being quite lengthy and involved, is not yet complete. Preliminary timings for the vectorized code are as follows (using the same conditions reported above for the original model):

Process Totals: 0.0065 sec/timestep
Diffusion: 0.0115 sec/timestep

As can be seen, the vectorized "Diffusion" pass is running over 100 times faster than the original code; the vectorized "Process Totals" pass is running about 3.5 times faster. It is anticipated that the eventual vectorized "Process Cells" pass

may run 10-20 times faster than the original code, so that, overall, the vectorized Run_Nutria_Model.m may run 40-50 times faster than the original code. Of course, running the model with extensive graphical interaction will slow even the vectorized code significantly; this appears to be unavoidable.

The conversion of the data structures from cell arrays to multidimensional matrices and the vectorization of the code are both tedious and error-prone tasks. We have written several routines that dump data structures at various points in the code to output files so that intermediate as well as final values in the model can be compared to those produced by the original code after each modification is made to the code, thereby ensuring that operation of the model remains unchanged. It is anticipated that it will take another 6 months or so to complete the remaining speedup modifications.



Photo 1. Nutria (*Myocastor coypus*) is an invasive mammal, which destroys coastal wetland habitats in Mississippi and Louisiana. Photo from the USGS Nonindigenous Aquatic Species webpage, <http://nas.er.usgs.gov/taxgroup/mammals/>

Task 4.

Extension and Outreach

Task 4.1.1. Aquatic Plant Extension Information

PI: John Madsen

Collaborators: Kurt Getsinger, USACE-RDC, Vicksburg, MS

Introduction:

While many terrestrial invasive plant species have numerous sources for factual information on the biology, ecology and control, most aquatic plant species have little available authoritative information on their biology, ecology and control in a format accessible to the public.

Approach:

We have undertaken an initiative to develop four-page fact sheets on the biology, ecology, distribution and management of invasive aquatic plants. While centered on Mississippi and the Mid-South, these fact sheets will be a valuable resource throughout the United States. Each fact sheet will discuss several alternative management techniques, and give specific rate recommendations for aquatic herbicides.



Photo 1. Underwater photo of Eurasian watermilfoil (*Myriophyllum spicatum*), showing the finely dissected leaves. Photo by John Madsen.

Results:

We have made significant progress on seven species during 2005, with another fourteen species planned for this fact sheet series (Table 1). The first two fact sheets completed as a final draft were for Eurasian watermilfoil (Photo 1) and curlyleaf pondweed (Photo 2), two submersed species that are widespread problems throughout the United States. We have also developed short web information and descriptions of invasive species on the GRI web page, available at: http://www.gri.msstate.edu/lwa/invspec/invasive_species.php. We provide a short description, a picture, and information on ongoing research at GRI for each species.

Table 1. Aquatic plants for which fact sheets are under development.
Fact sheet and information products

Species Common Name	Scientific Name	Status
<i>Under development in 2005</i>		
Beach vitex	<i>Vitex rotundifolia</i>	In review
Curlyleaf pondweed	<i>Potamogeton crispus</i>	To printing
Eurasian watermilfoil	<i>Myriophyllum spicatum</i>	To printing
Giant salvinia	<i>Salvinia molesta</i>	To printing
Hydrilla	<i>Hydrilla verticillata</i>	In review
Purple loosestrife	<i>Lythrum salicaria</i>	To printing
Waterhyacinth	<i>Eichhornia crassipes</i>	In draft
<i>To be developed in 2006</i>		
Alligatorweed	<i>Alternanthera philoxeroides</i>	To be drafted in 2006
American Lotus	<i>Nelumbo lutea</i>	To be drafted in 2006
Cabomba	<i>Cabomba caroliniana</i>	To be drafted in 2006
Egeria	<i>Egeria densa</i>	To be drafted in 2006
Fragrant waterlily	<i>Nymphaea odorata</i>	To be drafted in 2006
Giant cutgrass	<i>Zizaniopsis milacea</i>	To be drafted in 2006
Parrotfeather	<i>Myriophyllum aquaticum</i>	To be drafted in 2006
Phragmites	<i>Phragmites australis</i>	To be drafted in 2006
Roundleaf toothcup	<i>Rotala rotundifolia</i>	To be drafted in 2006
Torpedograss	<i>Panicum repens</i>	To be drafted in 2006
Variable-leaf watermilfoil	<i>Myriophyllum heterophyllum</i>	To be drafted in 2006
Waterchestnut	<i>Trapa natans</i>	To be drafted in 2006
Waterlettuce	<i>Pistia stratiotes</i>	To be drafted in 2006
Water primrose	<i>Ludwigia grandiflora</i>	To be drafted in 2006



Photo 2. Curlyleaf pondweed (*Potamogeton crispus*) growing in dense mats in Hennepin Lake, near Ottawa, Illinois. Photo by John Madsen.

Future Efforts:

During 2006, we will also work to develop an online reporting system for invasive aquatic plants, as part of a larger effort to map invasive plant species. The online reporting system will also have an ArcIMS map facility, to show the distribution of invasive plant species. We will also have the fact sheets available online, along with other pertinent information on each species.

Task 4.1.2. Aquatic Plant Management

Extension Information: Grass Carp Review

PI: Eric Dibble

Introduction:

Considerable amount of information has been written on the use of grass carp or white amur (*Ctenopharyngodon idella*) to control invasive aquatic plants. Ecological questions and concerns have been debated recently on the feasibility of using grass carp as a control method. To appropriately manage and protect freshwater communities a thorough understanding by managers and the public of their use and potential impacts on the environment are essential. Our objective of this task unit was to conduct a review of the currently literature to develop educational outreach reference. The data will be organized in two formats so information may be transferred as extension outreach: (i) a web page, and (ii) as a report document.

Preliminary results:

The following information has been provided and published the web:

The grass carp, or white amur (*Ctenopharyngodon idella*) is native to Asian and represents an exotic introduction to North America. The use of grass carp as a tool to control noxious aquatic plants probably began in Arkansas reservoirs during the 1960's with the hope it would control prolific plant growth. Because the animal has a ferocious appetite and its apparent success until the mid 1980's it was enthusiastically accepted as a feasible means to manage invasive aquatic plants. A triploid form of this exotic species is still a popular control agent in Mississippi and regularly stocked into artificially constructed reservoirs and farm ponds.



Grass carp are as omnivorous as herbaceous. Reports show they feed on more than fifty different food items, including aquatic plants, algae, invertebrates and

vertebrates. The most prevalent aquatic plants reported to be preferred by the grass carp are within the genera: *Myriophyllum* (milfoils), *Potamogeton* (pond weeds) and *Typha* (cattails). Under certain situations the fish has been known to avoid most of the plants typically eaten. Species reported most commonly avoided are within the genera: *Nymphaea* and *Nuphar* (pond lilies), and including *Potamogeton*, *Myriophyllum*, and *Typha*.



During the last 40 years, considerable amount of information has been written on the use of grass carp or white amur (*Ctenopharyngodon idella*) to control invasive aquatic plants, and for more than a decade, questions have arisen about the ecological feasibility of using grass carp for aquatic plant control in fear of accidental introduced into natural systems. Scientific concern and debate have prevailed about how this large exotic herbivore impacts freshwater ecosystems and more specifically how they may alter water quality and habitat important to a viable native plants and fish community.

Major reductions of aquatic plants and their complete elimination can be caused by foraging activities of grass carp when introduced into the system, and diversity within aquatic plant communities can be reduced considerably even at carp densities typically required to control for a targeted nuisance plant species. The change or loss of aquatic plants at this magnitude can easily alter the dynamic ecology and habitat of the organisms living in the system. To appropriately manage and protect freshwater communities a thorough understanding of the ecological relationship between grass carp and the rest of the aquatic community is essential.

A joint effort is currently underway by scientists at the GeoResources Institute and the Department of Wildlife and Fisheries at Mississippi State University to assess potential environmental impacts to natural freshwater habitat when grass carp are used as a bio-control agent against aquatic plants.

Task 4.2. Terrestrial Grass Extension Information

PI: John Byrd, Co-PI: John Madsen, Victor Maddox
Collaborators: Randy Westbrooks, USGS NWRC

Introduction:

Many terrestrial invasive plant species have numerous sources for factual information on their biology and ecology, but lack good information on their management. In addition, differences in climate between states are often significant enough that each region need accurate and authoritative information on invasive plants to that region.

Approach:

We will develop both printed and web-accessible information on invasive plants for Mississippi and the region.



Photo 1. Dr. Charles Bryson examines a fruit-bearing plant of tropical soda apple (*Solanum viarem*). Photo by John Byrd.

Results:

During the past year, we developed web presentations on tropical soda apple (*Solanum viarem*) and kudzu (*Pueraria montana*) to accompany the presentation developed for cogongrass (*Imperata cylindrica*) developed in 2004. The two new presentations are in the queue to be posted on the invasive species site, <http://www.gri.msstate.edu/lwa/invspec.php>.



Photo 2. Aerial photograph of kudzu (*Pueraria montana*)-infested fields. Photo by John Byrd.

Future Efforts:

During 2006, information will be developed on tropical spiderwort (*Commelina benghalensis*) and Chinese tallow tree (*Triadica sebifera*).

Task 4.3. Cactus and Cactus Moth Extension Information

PI: John Madsen

Co-PI: Richard Brown, John Byrd, Victor Maddox, Clifton Abbott

Collaborators: Randy Westbrook, Annie Simpson

Introduction:

The potential spread of the cactus moth in North America from Florida to the southwestern US and Mexico is an issue of great economic and ecological concern. We will develop web-based information to aid in the identification of cactus and the cactus moth, provide an avenue for reporting suspected locations on the web, and web GIS database to display the movement of the moth and locations of natural cactus populations. The products generated will inform the general public of the cactus moth issue, and assist in building and training volunteers for monitoring sites.

Approach:

We have developed a cactus moth database webpage (http://www.gri.msstate.edu/cactus_moth) for use with our volunteer monitors (described further later in the report), and have used this site as well for disseminating information on cactus moth. Cactus moth information is also available at the GRI invasive species webpage (<http://www.gri.msstate.edu/lwa/invspec.php>) with links to other useful sites (http://www.gri.msstate.edu/lwa/invspec/cactus_moth.php). The information products are designed to build towards a training course for volunteer monitors.



Photo 1. Pricklypear cactus infested with cactus moth.



Photo 2. Cactus moth larvae are gregarious and distinctive in appearance. Photo by David Habeck, University of Florida.

Results:

We have developed ten print items, in addition to the web pages, that provide information on pricklypear cactus and cactus moth (Table 1). These items have been used to train some volunteers in Mississippi, but further work is needed on a volunteer monitor training course.

Table 1. Cactus and cactus moth extension products under development.

Topic	Authors	Status
The Cactus Moth Detection and Monitoring Network Webpage, http://www.gri.msstate.edu/cactus_moth	Clifton Abbott, webmaster	Online (development continuing)
Brochure: The Cactus Moth: An Invading Pest	Richard Brown and Edda Martinez	Completed
Report: Survey Information for the National Cactus Moth (<i>Cactoblastis cactorum</i>) Detection and Monitoring Network	Joel Floyd and John Madsen	Submitted for publication
Early Detection and Reporting of Cactus Moth in the U.S.	R.G. Westbrooks, J.D. Madsen, R.L. Brown	Submitted for publication
Handout: Have you seen <i>Opuntia</i> ?	Victor Maddox	Completed
Factsheet: Identification of pricklypear cactus	Victor Maddox	In review
Factsheet: Erect pricklypear cactus	Victor Maddox	Submitted for publication
Factsheet: Cockspur pricklypear cactus	Victor Maddox	Submitted for publication
Factsheet: Devils Tongue pricklypear cactus	Victor Maddox	Submitted for publication
Factsheet: Tuna pricklypear cactus	Victor Maddox	Submitted for publication

Future Work:

We will be developing a volunteer monitor training course that can be implemented in a workshop format, with plans to develop a web-based training module.

Task 4.4. Web-based Database of Invasive Species Locations

PI: John Madsen

Co-PI: David Shaw, John Byrd, Clifton Abbott

Collaborator: Randy Westbrook, USGS National Wetland Research Center; Annie Simpson, National Biological Information Infrastructure

Introduction:

Cactus moth (*Cactoblastis cactorum* Berg.) is a widely used biological control agent of pricklypear cactus in Australia and South Africa. Cactus moth appeared in the Florida Keys in 1989, spreading as far as South Carolina and Alabama. Cactus moth quickly destroys a stand of pricklypear, and is a threat to natural biodiversity, horticulture, and forage in the southwestern United States and Mexico. USGS, USDA-APHIS, and Mississippi State University have formed the National Cactus Moth Detection Network, composed of volunteer monitors from public and private land management units, garden clubs and Master Gardeners to monitor the spread of the moth. Volunteers will report observations using a web-based database (www.gri.msstate.edu/cactus_moth). In addition to providing information on the threat posed by cactus moth, this web page offers data searching and data entry capabilities, including an interface for GIS-enabled handheld PDAs. The database will be an important tool for management of cactus moth.

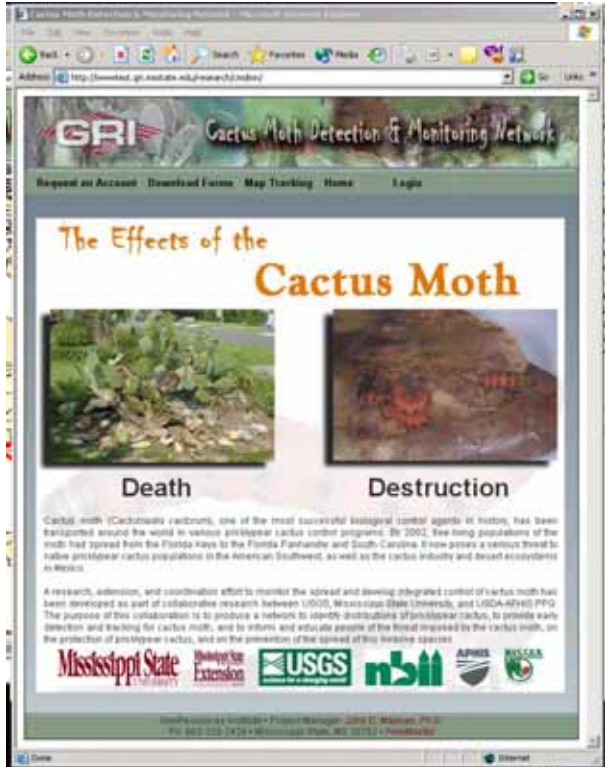

Photo 1. The Cactus Moth Detection and Monitoring Network Webpage, http://www.gri.msstate.edu/cactus_moth

Materials and Methods:

Concerned about the potential damage caused by the cactus moth, a partnership has been formed between federal agencies (USGS BRD, USDA APHIS), state agencies (states Departments of Agriculture), Universities (Mississippi State University), Cooperative Extension, and other interested groups to monitor the distribution of the cactus moth. The program relies on volunteers, which may be either concerned citizens or professionals at land management entities, to monitor cactus populations (Table 1). This is the first step of an Early Detection and Rapid Response (EDRR) approach, with USDA APHIS developing a sterile insect (SIT) release protocol for control of the moth.

Table 1. National Cactus Moth Detection and Monitoring Network partnering agencies.

Agency or Group
Federal
National Invasive Species Council
U.S. Department of Agriculture
Agricultural Research Service
Animal and Plant Health Inspection Service
Cooperative State Research, Education and Extension Service (CSREES)
U.S. Forest Service
U.S. Department of Defense
U.S. Department of Interior
Bureau of Land Management
National Biological Information Infrastructure
National Park Service
U.S. Fish and Wildlife Service
U.S. Geological Survey Biological Resources Discipline
State
Mississippi Department of Agriculture and Commerce
University
Mississippi State University
GeoResources Institute
Mississippi State University Extension Service
Non Government Organizations
Mississippi Master Gardeners
NatureServe
The Nature Conservancy

Likely areas are surveyed for pricklypear cactus. Specific data on the cactus are recorded, including the precise location using a GPS, if available. The volunteer, a coordinator, or Mississippi State University personnel enter the data into the web-based database (below). All cactus moth identifications must be made by trained

personnel, and verified by Dr. Richard Brown, the MSU lepidopterist. New records for states must follow further verification procedures. Appropriate personnel verify data entered into the system before being finalized in the database. The survey process is explained further in a draft manual, available to volunteers and collaborators (Floyd and Madsen 2005).

The Cactus Moth Detection and Monitoring Network web-based database is located at http://www.gri.msstate.edu/cactus_moth and has menus for requesting an account, downloading forms or information, map tracking, and a login access. All data are entered by registered users via this web-based system. The first step for a volunteer is to become a registered user by requesting an account via the website. The accounts are individually approved, to prevent false data entry.

Anyone visiting the site can download forms and information. Forms for collecting data on pricklypear sites, visual observations of cactus moth life stages on the cactus, and cactus moth trap forms are provided. Each form has a variable explanation sheet to explain the data being collected. In addition, any visitor can download a survey manual, cactus moth brochure, fact sheet on the National Cactus Moth Detection and Monitoring Network, and a pricklypear identification handout for the southeastern U.S. (native cacti only). Another feature that is still under development is an ArcIMS map utility that displays all cactus sites investigated. In the near future, cactus moth locations will be an active layer for the ArcIMS map.

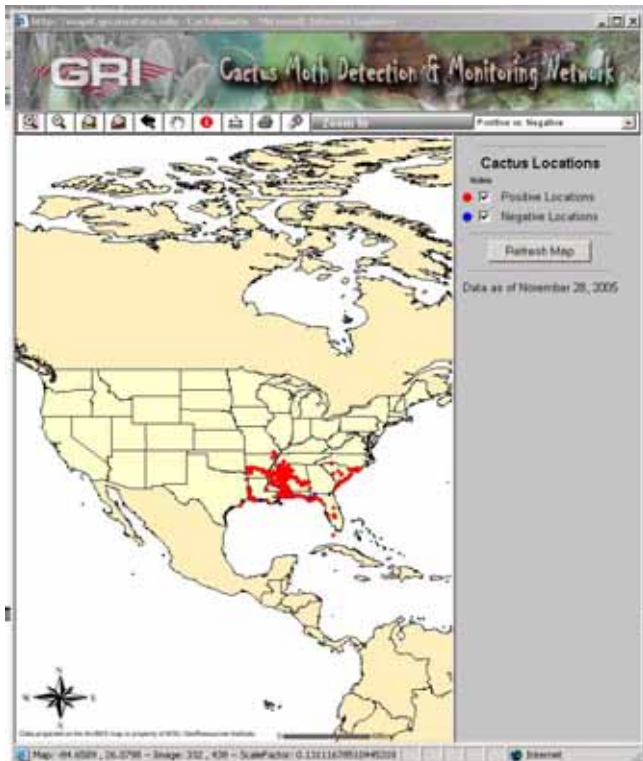

Photo 2. ArcIMS Map showing the Pricklypear distributions.

Results and Discussion:

The Cactus Moth Detection and Monitoring Network came online early 2005, and was opened to the public in June. To date, there have been 851 pricklypear reports submitted with 776 being positive sightings of cacti. These reports came from 12 different collectors spanning 10 states. There have been 783 moth reports submitted with 56 being positive sightings of the invasive cactus moth. Of those 56 reports, 51 are part of the “historical” sightings throughout the Southeast made by Stephen Hight.

The online GIS map created from the database provides a visual representation of the detection and monitoring system, which may be used by collectors to identify areas in which there are gaps in the survey. Collectors are then able to plan survey trips into those areas that are lacking observations. The map is also being used to identify potential sentinel site locations on or around the leading edge of the moth’s progression. Incomplete reports can also be shown on the map. Incomplete reports are locations that are marked as having incomplete information and needing an onsite visit. These reports may be those that came from the public or from herbarium records and the only information known is that there is, or was, cactus present. The GIS map allows collectors who are planning survey trips to plan a visit to these incomplete sites that happen to be close to their route.

The GIS map has become useful for other reasons as well. County boundaries, zip code boundaries, roads, and urban areas are displayed to help collectors find routes to certain areas, or to find their way to a certain cactus location. These data layers are also used for reports that have poor descriptions on their locations. Better, or more complete, location descriptions can be obtained. Areas can be zoomed into, maps can be made for printing or publication purposes, and reports can be queried to provide certain survey information on that location. Hurricane storm tracks with wind data are being added as a data layer to the map to identify which cactus/moth locations are most likely to be effected by winds and surge. Cactus and moth locations that are no longer present due to storm eradication need to be identified and the GIS map provides the means to do just that.

The reports that are submitted to the system are being used to model cactus locations in an effort to help predict where cacti are likely to be located. Using this information, collectors can identify areas that have high potential in containing cactus and possibly the cactus moth.

Literature Cited:

Floyd, J. and J.D. Madsen. 2005. Survey Information for the National Cactus Moth (*Cactoblastis cactorum*) Detection and Monitoring Network. Mississippi State University Extension Service, draft June 2005.
http://www.gri.msstate.edu/cactus_moth/download/CactusMothSurveyManual.pdf

Task 5.

Regional Coordination

Task 5.1. Developing a State Invasive Species Alliance for Mississippi

PI: John D. Madsen, Mississippi State University, GeoResources Institute
Co-PI: John D. Byrd, Jr., David R. Shaw, Mississippi State University,
GeoResources Institute, and Randy G. Westbrooks, U.S. Geological Survey,
Biological Resources Discipline

Abstract:

Invasive species create multi-billion dollar problems in the mid-south states. While a number of federal, state, and local agencies have responded with small programs to manage these problems, cost-effective management requires early detection and rapid treatment on small populations. The proliferation of programs lacks effective communication and coordination between states and agencies. Individual development of tracking new infestations and data sharing would be wasteful duplication of funds. We are developing a task force of local, state, and federal government agencies, nongovernmental organizations and concerned citizens who are focused on the early detection and management of invasive noxious species in Mississippi, the Mississippi Invasive Species Alliance (MISA). The organization will be tiered, having an executive council of decision-makers from each state, a technical steering committee, and an advisory council composed of those interested in participating. The MISA will coordinate the sharing of data, act as a clearing house for locations of invasive species in the region, facilitate information exchange at the appropriate federal level, and act to coordinate regional management efforts.

Introduction:

Invasive species are now found in virtually every natural and managed ecosystem in Mississippi. Kudzu infests rights of way, forests, and pastures, creating a variety of nuisance problems. Cogongrass is invading a host of terrestrial sites, increasing fire hazard and damages to timber production. Waterhyacinth, hydrilla, and the rodent nutria are all examples of aquatic invasive species that impact natural resources. These pests cost the economy millions of dollars in damages and indirect losses, as well as the cost of pest management. We propose to develop and implement a task force of federal, state, and local government agencies, nongovernmental organizations and concerned citizens focused on the early detection and management of invasive noxious species in Mississippi, which will be named the Mississippi Invasive Species Alliance (MISA).

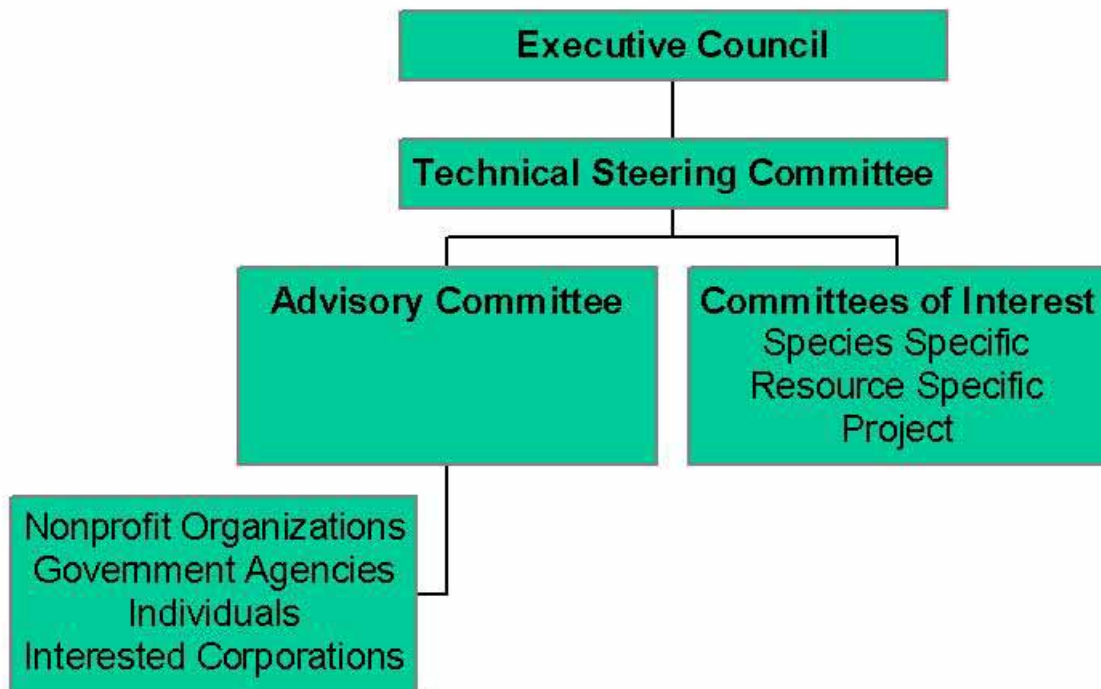

Figure 1. Structure of the Mississippi Invasive Species Alliance.

The MISA will have tiered participation, an Executive Council of decision-makers from each state or federal agency, a technical steering committee, and an advisory council composed of those interested in participating. While Mississippi State University’s GeoResources Institute will act to coordinate early formation and serve as the data clearinghouse and Geographical Information Center (GIS) center, the MISA will be self-governing.

The MISA will coordinate the sharing of data, act as a clearing house for locations of invasive species in the state, facilitate information exchange at the appropriate federal level, and act to coordinate funding of in-state management efforts.

With the suggested formation of this alliance, the obvious questions are 1) what is the structure and function of this group, 2) why is another group needed, and 3) how will MISA relate to other existing groups.

Structure of the Mississippi Invasive Species Alliance:

The structure of the Mississippi Invasive Species Alliance was inspired in part by the highly successful Cogongrass Task Force in the State of Mississippi. Started at the grass roots by interested landowners, they immediately engaged federal, state and local government agencies involved in the issue, and sought complementary funding to address the cogongrass problem.

We are proposing a tiered approach, with an Executive Council of decision-makers from major agencies or organizations, a Technical Steering Committee, and an Advisory Committee composed of those interested in participating. The alliance will coordinate the sharing of data, act as a clearing house for locations of invasive species in the region, facilitate information exchange at the appropriate federal level, and act to coordinate funding of regional management efforts.

Executive Council. The Executive Council will be composed of decision-makers from the major agencies involved in invasive species issues, including federal and state agencies, extension, and nonprofit organizations (Table 1). The Executive Council will act upon the recommendations of the Technical Steering Committee, and will be able to enact into policy, regulation, or executive action at the governmental level appropriate recommendations from the Technical Steering Committee.

Table 1. Representation on the Mississippi Invasive Species Alliance Executive Council.

Person or Agency
Chair: David Shaw, Mississippi State University – GeoResources Institute
Mississippi Department of Agriculture and Commerce
Mississippi Department of Wildlife, Fisheries, and Parks
Mississippi State University Extension Service
The Nature Conservancy
US Department of Agriculture

Technical Steering Committee. The Technical Steering Committee will be the workhorse of the MISA, with representation from federal and state agencies and nonprofit organizations (Table 2). The chairs of the Executive Council and Advisory Committee will be ad hoc members of the Technical Steering Committee.

Table 2. Representation on the Mississippi Invasive Species Alliance Technical Steering Committee.

Person	Agency
Chair: John Byrd	Mississippi State University - Extension Service
Charles Bryson	USDA – ARS
Jeffrey Head	USDA – APHIS - PPQ
Walter Jackson	USDA – NRCS
Michael Tagert	Mississippi Department of Agriculture and Commerce
David Thompson	Mississippi Department of Transportation
Lisa Yager	The Nature Conservancy
John Madsen (Non-voting; Advisory Council Chair)	Mississippi State University – GeoResources Institute
David Shaw (Nonvoting, Executive Council Chair)	Mississippi State University – GeoResources Institute

Advisory Committee. The Advisory Committee will be open to all interested persons in Mississippi, and will allow access to information, coordination, and an opportunity to participate in decisions on priorities (Table 3). The Advisory Committee will meet at least once per year. At other times, information will be disseminated to the Advisory Committee e-mail list.

Table 3. Preliminary list of invitees to the Mississippi Invasive Species Alliance Advisory Council. Membership is unlimited and open to all interested in invasive species issues.

Person, Group or Agency
Chair: John Madsen, Mississippi State University – GeoResources Institute
National
U.S. Bureau of Land Management
US Department of Defense
The Nature Conservancy
U.S. Army Corps of Engineers
U.S. Fish and Wildlife Service
U.S.D.A. Forest Service
U.S.D.A.-APHIS
U.S.D.A.-ARS
U.S.D.A.-NRCS
Tribal
Mississippi Band of Choctaw Indians
State
Alcorn State University
Delta Council
Delta State University
Delta Wildlife
Mississippi Land and Timber Resources Board
Mississippi Cattlemen’s Association
Mississippi Department of Agriculture and Commerce
Mississippi Department of Environmental Quality
Mississippi Department of Marine Resources
Mississippi Department of Transportation
Mississippi Department of Wildlife, Fisheries, and Parks
Mississippi Farm Bureau Federation
Mississippi Forestry Commission
Mississippi Levee Board
Mississippi Natural Heritage Program
Mississippi Public Service Commission
Mississippi Soil & Water Conservation Commission
Mississippi State University
National Atmospheric and Space Administration
The Garden Clubs of Mississippi
University of Mississippi
University of Southern Mississippi

Project Committees. In addition, existing species-specific or resource-specific groups may interact directly with the Technical Steering Committee through its members to address areas of mutual concern. For instance, the Cogongrass Task Force may interact directly with the Technical Steering Committee on issues of mutual interest. Within the MISA, species-specific (e.g., kudzu) or resource-specific committees may be formed to more intensely focus on those problems, without losing communication or competing for funding.

Why Do We Need Another Group?

The invasion of a profusion of species impacting all aspects of our national ecosystem has generated considerable concern among natural resource managers and scientists, resulting in the formation of a number of groups focused on invasive species issues. Some focus on a given species, while others focus on resource types or habitats. Many of these groups have been effective in their targeted goals, others less so. Why do we need another group?

First, scientists or resource managers start most of these groups, for scientists and natural resource managers. They do not specifically include decision makers and people of influence, to enact their goals into policy. The Mississippi Invasive Species Alliance will incorporate these state policymakers into an Executive Council, to include them in the process.

Second, the very proliferation of these groups has created a new problem – these groups compete for attention and resources. While MISA will not seek to replace these groups in any way, it will seek to present a coordinated front to the public and legislators to minimize this competition for resources and attention.

Last, most of these groups cannot devote the necessary resources to develop and maintain web-based databases and information resources on the invasive species problems in the state. We are seeking to provide this information node for invasive species groups and target species for the state.

How MISA Relates to Other Existing Groups:

The MISA will actively seek cooperation and collaboration with existing invasive species groups in the state and country, develop linkages where mutual interests occur, and provide information flow for all groups. Given our base in the extension service nationwide, we will also seek to provide information through a broader network on invasive species concerns. We will work with local, state and federal agencies to provide timely information on the locations of target invasive species through a web-based database. We will work with professionals and volunteers in training, education, and resources to find new locations of invasive species, and monitor their distribution.

Task 5.2 Mid-South ISA Formation

PI: David Shaw

Co-PI: John Byrd, John Madsen

Collaborator: Randy Westbrook, USGS National Wetland Research Center

Invasive Species Management Tour: Lower Coastal Plain Habitat Restoration

The GeoResources Institute (GRI) of Mississippi State University hosted a tour and informational meeting on invasive species management for restoration of lower coastal plain ecosystems. The tour was co-sponsored by the Mississippi Invasive Species Alliance, the Southern Weed Science Society, and BASF. Approximately 50 participants from federal, state, and local government agencies throughout the Southeast attended the tour during the three days, October 6-8, 2004, representing activities in the mid-south states of Alabama, Arkansas, Louisiana, Mississippi, and Tennessee.

On Wednesday October 6, the tour began with an in-depth examination of Longleaf Pine restoration on the Judd Brooke's Plantation near Nacaise, MS. Participants received an up-close view of the interrelationship between land management, invasive species management, wildlife management and economics in the restoration of this significant community. Longleaf pine restoration and management involves a close working relationship between the private landowner and county, state, and federal agencies.



Photo 1. Tour participants hear about prescribed burns as a management technique for longleaf pine plantations. Cogongrass burns too hot for prescribed burned management.



Photo 2. Lisa Yager of The Nature Conservancy discusses rare and endangered plant communities in longleaf pine ecosystems.

On the second day of the tour, participants had a full day of activities. The day began by viewing how important the link between university research, extension and outreach, and resource management agency collaboration can be in the battle with invasive species. Cogongrass management research plots were the first stop, with an informational presentation by the study director, Dr. John Byrd of Mississippi State University.



Photo 3. Dr. John Byrd discusses cogongrass management studies.

Herbicide application rates and product selections developed by research plots were then used in interagency demonstrations near Pascagoula, a cooperative project of MS Department of Transportation, Mississippi Department of Environmental

Quality, and Mississippi State University. After lunch, we viewed the Mississippi Department of Transportation's efforts to control Chinese Privet along highway rights of way in southern Mississippi, and the tropical soda apple project eradication efforts in the joint program of USDA APHIS and Mississippi Department of Agriculture and Commerce, Bureau of Plant Industry.

After these tour stops, participants returned to the Judd Brooke's Plantation to view local education and outreach efforts on cogongrass management and longleaf pine restoration. This portion of the program, the Forestry and Wildlife Field Day, was an effort by Hancock County, Mississippi State University Extension Service, and USDA Natural Resource Conservation Service and USDA Forest Service for management of private forests.



Photo 4. Tour participants travel in style on the Judd Brooke's plantation.

Presenters included representatives from US Fish and Wildlife Service, USDA Natural Resources Conservation Service, Mississippi Forestry Commission, Mississippi State University and Extension Service, The Nature Conservancy, BASF, and private consultants. Field tour topics included cogongrass management, longleaf pine forest management, conversion of slash pine to longleaf pine forests, plant diversity and the importance of blanket bogs in the longleaf pine ecosystem, demonstration of mechanical and chemical forestry management practices, and federal cost share programs. Over 100 landowners and local residents came to participate in this informational tour, which was followed by a catfish dinner and presentations on invasive species, wildlife management, and remote sensing.

On the third and final day of the tour, the Mississippi Invasive Species Alliance hosted an informational and organizational meeting to discuss the possible formation of a Mid-South Invasive Species Alliance. Twenty-two invited participants from state and federal agencies from Alabama, Arkansas, Louisiana, Mississippi and Tennessee attended this meeting. Dr. David Shaw (GRI) and Dr. Randy Westbrook (US Geological Service Biological Resources Discipline) first discussed the impetus for a regional effort at cooperation and coordination between

agencies and groups focused on all invasive species efforts. These presentations were followed by a state-by-state discussion of invasive species management activities. The attendees agreed to the need for an effort between these states and the diverse efforts on managing invasive species to cooperate and coordinate more fully, and outlined future steps to take towards a more formal organization.

For information on the Mississippi Invasive Species Alliance, or to find out more about regional efforts and the formation of a Mid-South Invasive Species Alliance, contact Dr. John Madsen, GeoResources Institute, Box 9652, Mississippi State, MS 39762, by telephone at 662-325-2428, or by email at jmadsen@gri.msstate.edu. You may also visit the GeoResources Institute web site at www.gri.msstate.edu.

Collaborators

